

SWISSPEARL ARCHITECTURE #24

PERFORATED

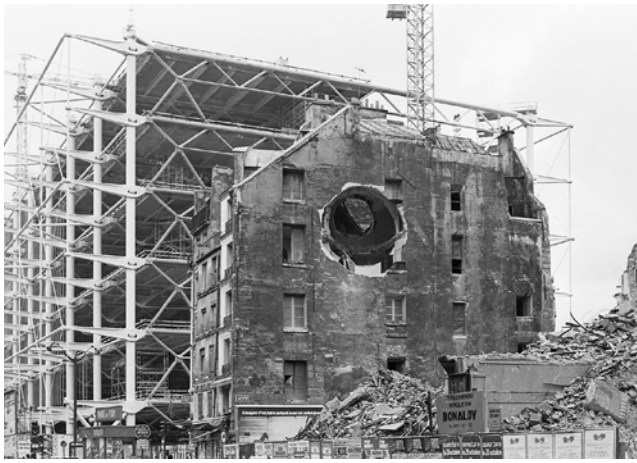



EDITORIAL

Perforations take on a variety of forms and can be arranged in different ways. Sometimes they appear as circular holes in rows of regular intervals, more commonly, however, they are playfully distributed in freeform geometric shapes. Sometimes perforations extend over an entire building volume, other times they form partial clusters. Sometimes the drilling or cut does not completely perforate the outermost layer, but instead, is placed purely for a visual effect. Thus arising are linear structures through to random, abstract patterns, and representational depictions. A perforated façade's appearance changes depending on whether the beholder or inhabitant perceives it from up close or far away.

In many cases, practical concerns become linked to visual ones—and vice versa. Openings that allow light and air to enter are in line with the basic requirements that building envelopes must fulfill. Also present are demands with regard to a building's appearance. Perforations are especially suitable for opening the exterior wall in a controlled way, and at the same time, achieving an impressive visual effect.

Fiber cement lends itself to all kinds of perforations: the solid, homogenous material can be drilled and cut without difficulty. Architecture journalist Patrick Zamariàn presents in this issue of *Swisspearl Architecture* various applications and shows what architecture is capable of with *Swisspearl*. Pascal Zürn, Foreman of panel fabrication and finishing at *Swisspearl*, comments on the technical parameters and practical requirements.

Perforations on buildings' walls and envelopes have roots in the centuries-old Arabic tradition of *mashrabiyya* latticework membranes between spaces. The Swiss architect Thomas Meyer-Wieser has researched masterpieces of oriental building culture for many years and forges a link for us to Western modernism.

We hope you enjoy looking at, and through!

Michael Hanak, Editor-in-chief

Left: "Conical Intersect" by the artist Gordon Matta-Clark, Paris, 1975.

PERFORATED

Report by Patrick Zamariàn

2 FUNCTIONAL ORNAMENTATION

EXTERNAL APPLICATIONS

- Switzerland, Weberbuess Architekten
- 9 WORKS YARD, BASEL

- Italy, S.O.F.A.
- 13 ELEMENTARY SCHOOL, LAAS

- USA, Dougherty & Dougherty
- 17 CORONA DEL MAR MIDDLE SCHOOL ENCLAVE, NEWPORT BEACH

PARTIAL APPLICATIONS

- Switzerland, OOS Architekten
- 22 COMMERCIAL AND OFFICE BUILDING HIAG, AATHAL-SEEGRÄBEN

- Switzerland, Baureag Architektengruppe
- 26 "GASTHAUS POST" EXTENSION, WILLISAU

- Switzerland, Moro e Moro
- 30 ORIZIA APARTMENT BLOCK, LOCARNO

- Croatia, Sangrad + AVP
- 34 EDUCATIONAL COMPLEX KAJZERICA, ZAGREB

PRIMARY APPLICATIONS

- Portugal, Saraiva & Associados
- 43 OFFICE BUILDING TAGUS GÁS, CARTAXO

- Hungary, 4 plusz Építész Stúdió
- 47 PARSONAGE, PARISH CHURCH OF THE CELESTIAL QUEEN, BUDAPEST

- USA, Dake Wells Architecture
- 51 MSU DAVIS-HARRINGTON WELCOME CENTER, MISSOURI STATE UNIVERSITY, SPRINGFIELD

- Slovenia, Superform
- 57 KINDERGARTEN, CERKVENJAK

Essay by Thomas Meyer-Wieser

- 61 MASHRABIYYA—THE ORNAMENT AS VISUAL CONCEPT

SMALL FORMAT

- 64 EMBROIDERED FAÇADE

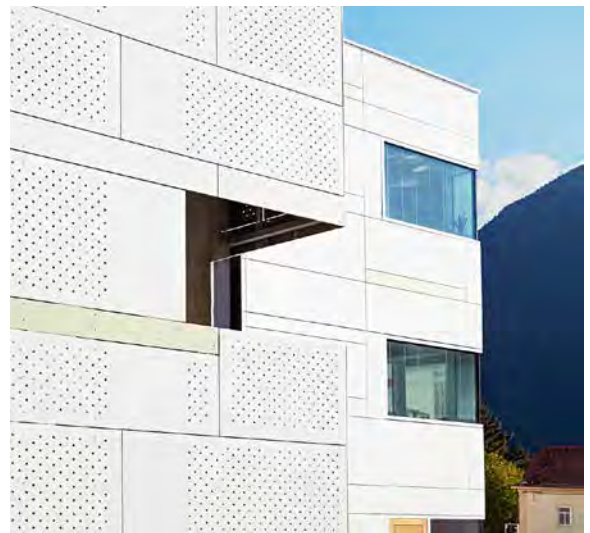

13

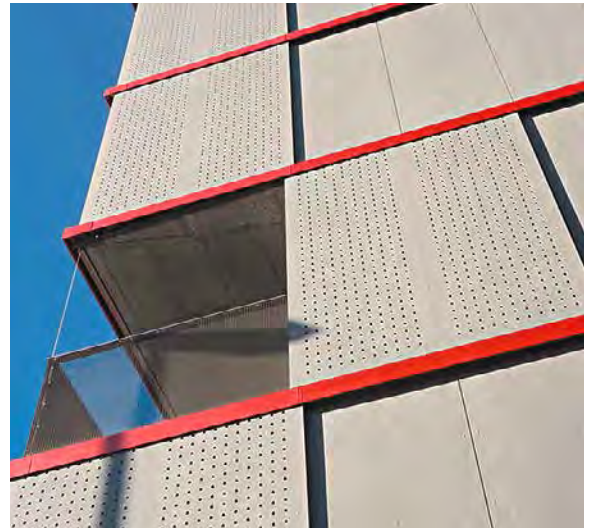

30



51



FUNCTIONAL ORNAMENTATION

Report by Patrick Zamariàn



The occurrence of perforated façades is a relatively recent, if all the more conspicuous phenomenon. This introductory article explores the theoretical implications of punctured claddings and their design potential in contemporary architecture. The material properties of Swisspearl panels make them uniquely suitable to cover the entire spectrum of possible applications, a great number of which are illustrated in this issue of “Swisspearl Architecture.”

Writing against the backdrop of a period marked by stylistic excesses and an obsession with surface values, Adolf Loos’s seminal polemic *Ornament and Crime*, first published in 1910, set the tone for the nascent modern movement. Inspired by Sullivan’s famous dictum “form follows function,” developments in the early twentieth century culminated in the emergence of a so-called “International Style,” which, though never quite as cohesive as suggested, was notable for the absence of any kind of architectural ornament and the removal of aesthetic considerations from the architectural equation.

The remarkable resurgence of ornamental features after World War II owed much to Le Corbusier, whose influential work incorporated elements derived from non-European vernaculars. Wide awnings and *brise-soleils* served a distinctive functional purpose in their countries of origin, but transferred to the northern hemisphere they soon became the decorative paraphernalia of Brutalist architecture. The advent of postmodernism in the early 1970s consolidated the revival of aesthetic values and reasserted the façade as a communicative medium and carrier of meaning. In doing so, postmodern architecture implied and effectively necessitated a segmentation of the building envelope into a load-bearing structural layer and a potentially independent outer skin. What first ap-

peared to be little more than a fashionable departure from orthodox modernism turned out to be a paradigm shift, as it coincided with a growing concern for environmental issues and a corresponding evaluation of building technologies, which, in turn, led to the demise of monolithic wall systems in favor of multilayered—and often lavishly decorated—building envelopes.

Aesthetic and functional

The occurrence of perforated wall claddings is part of this revival of ornamentation in contemporary architecture and is driven by recent technological advances. Loos’s uncompromising critique of ornaments, somewhat narrowly interpreted as applied decoration, was centered upon the fact that it involved skilled craftsmen in manufacturing products which were, by definition, without practical purpose—a process that he not only considered to be meaningless, but more importantly wasteful of human labor and material expenditure and therefore morally reprehensible. None of these arguments remains valid in the context of today’s building production. The rise of computer-controlled manufacturing technologies means that perforated designs, regardless of their scope and complexity, no longer need to be cut by hand and therefore do not entail any significant additional costs, monetary or otherwise. More-



over, involving, as they do, a process of deduction rather than supplementation, perforations appeal even to architects of a comparably sober disposition, who frequently use them as adornment to otherwise strictly functional buildings. In light of this, it is perhaps not surprising that they appear to be particularly popular in countries with a proud minimalist tradition, such as Switzerland and Japan.

Most importantly, although perforations can have—and often do have—a profound impact on the visual appearance of a building, they differ from any other sort of façade embellishment in that they are justifiable on functional grounds, not least because they play a vital part in improving the comfort levels in interior spaces. In almost all cases, perforated panels are used in combination with glass surfaces, regulating the penetration of natural light and air whilst providing building occupants with a measured degree of visual protection and privacy. Moreover, by shading extensively glazed frontages, perforated panels prevent excessive solar gains, thus reducing the load on HVAC systems and significantly enhancing the building's energy performance—a key selling point in times of scarce resources and high energy costs.

The inherent simultaneity of aesthetic and functional purposes is the distinguishing characteristic of perforated façades. It imposes an exacting, if highly rewarding disci-

pline on designers in that it requires, but also enables them to address such fundamental architectural dichotomies as inside and outside, enclosure and space, solid and void, beauty and purpose. The range of applications is accordingly wide and, considering that perforated walls are a comparably recent addition to the modernist vocabulary, presumably far from exhausted.

Three types of applications

Generally speaking, applications can be divided into three categories, depending on their scope and function within the broader design conception. Used as single-layered dividers between outside or, more precisely, non-insulated spaces, perforated panel walls most closely resemble their origins as low-tech climate control devices in tropical and subtropical regions. In temperate climates such external applications are comparably rare and confined to uninhabited spaces, such as escape corridors, terraces, and, most notably, balconies. For instance, M & M Consulting's retirement home in Grosuplje features pierced sliding screens that enable residents to demarcate a shaded and sheltered zone on their balconies, while One Works used perforated panels superimposed on a continuous balcony layer to give vertical emphasis to their Noverasco shopping center. In the majority of cases, perforations are applied to

specific façade elements and play a subordinate role within the overall design. Often used as pierced shutters reminiscent of Arabian *mashrabiyyas*, the main objective is to feed a controlled measure of light and air into the interior without visually breaking up the façade as a whole. Like their Arabic prototypes, they thus create a sense of one-way permeability, allowing building users to obtain a view of their surroundings while remaining hidden from view themselves. It is thus no surprise that punctured screens are often used in connection with bathroom windows and private bedrooms where a degree of illumination and ventilation is desirable without compromising either the privacy of residents or the integrity of the façade.

With the possibility to produce large-scale patterns in a cost-effective way, architects increasingly wrap entire walls—or indeed entire buildings—in comprehensive perforated paneling. At times, this seems merely a convenient, if visually appealing measure to conceal untidy elevations behind a unifying veil. However, more ingenious designers fully embrace the expressive potential of perforations by making them the primary design element, which defines the character of the building as a whole. A prime example of this tendency is Gužič and Trplan's bus station at Velenje where punctured vertical sun blinds give a refined, almost ethe-



Work preparation: the CNC machine is programmed panel for panel based on the delivered plans. A production worker prepares the milling machine.



real quality to the main glass frontage, while the white Swisspearl cladding of the parking garage displays an irregular pattern of circular holes that recalls a traffic signal board, advertising the facility's designation as a transportation hub. The distinction between primary and subordinate applications is evidently a gradual one and open to interpretation. It is, however, important to realize that the visual impact of perforations is not fundamentally a matter of scope. The question as to whether they sustain or dissolve the integrity of the façade depends on the shape, size, and spacing of the openings and, crucially, the brightness and color of the cladding itself, which determines the conspicuousness and visual prominence of the black perforation pattern.

Advantages of Swisspearl panels

Swisspearl is not the only cladding material that can be perforated. Herzog and de Meuron used pierced and dimpled copper plates for their De Young Museum in San Francisco; Coop Himmelb(l)au wrapped their BMW World in Munich in stainless steel sheets; and David Adjaye's Smithsonian National Museum of African American History and Culture, currently under construction in Washington DC, will be encased in punctured bronze plates. These examples, spectacular though they are, at the same time

highlight the limitations of comprehensive perforated metal façades: eminently suited for a small selection of high-profile signature buildings, they are, in equal measure, inappropriate for most other building tasks where a more subtle, contextual approach seems desirable.

Indeed, the superior appeal of perforated Swisspearl fiber cement panels lies in their versatility, which allows them to cover the entire spectrum of external, primary, and partial applications. Swisspearl panels are available in customizable colors and formats and a broad range of transparent, pigmented, iridescent, or textured coatings, which makes it possible to combine them freely with each other as well as with other materials. Their singular asset, however, is the unique monolithic aesthetic of the integrally colored panel base and its implications for the quality of finishes. As far as perforated metal sheets are concerned, holes are punched or laser-cut, which either distorts the edges or leaves burn marks. Though there are ways to turn them back into flat, usable plates, corrective leveling is a demanding task and the outcome often leaves much to be desired. In contrast, Swisspearl engineers use state-of-the-art CNC cutting machinery, which enables them to finish the edges of perforations to the same unrivaled quality standard as the panels themselves.

In addition, Swisspearl, unlike many other manufacturers, does not confine their range to standard perforation patterns, and there is almost no limit to the imagination of designers and the intricacy of their creations. John Ronan devised cross-shaped perforations for the chapel of his Jesuit school in Chicago, whilst SWECO proposed a pattern of triangular perforations for the tunnel lining of their underground railway station in Malmö, called Triangeln, both size and shape of the openings carefully calculated to absorb the echo effect on the platform. To guarantee the rigidity of the cladding, Swisspearl recommend that perforations should not exceed 20 percent of the total panel surface, the distance between holes should be a minimum of twice their diameter, and the panel should feature a perforation-free border to allow for fixing through Sigma undercut anchors (with ordinary screw fasteners offering slightly more flexibility). However, these are merely guide values, as Swisspearl engineers collaborate closely with architects to turn their visions into workable design solutions—such as the ones illustrated in this issue of *Swisspearl Architecture*.

KNOW-HOW

Perforated or engraved panels can be used for many purposes, for acoustic or aesthetical reasons, to depict works of art, letters, logos, etc.

However, the fabrication process is rather labor intensive both for preparation work and also for the actual routing out of shapes and drilling of holes. Decisive is whether the panels are used for exterior or interior application. For exterior applications, i. e., increased exposure to weathering, the panels are first primed, then fabricated and subsequently coated.

For interior use, coated panels can be drilled or routed and then left as they are.

When individual CNC routing must be programmed on the basis of CAD drawings, the process takes two or three times longer than for standard perforations. This is the case especially for irregular and randomly located patterns.

For perforated or engraved panels, various aspects have to be considered. In addition to the designed shapes and patterns, the panel stability and fastening of the panels is crucial, distances between perforations or engraved areas should not be too small, and for larger panels, a solid perimeter zone is required, so that the panels are not too fragile for handling on site and installation.

Common drill hole diameters are 6 or 8 mm; since these panels are not coated after fabrication, they are for interior application only. These small diameter holes are located in a grid of 16/32/48 mm in both directions. For exterior applications or if the panels must be washable, a minimum 20 mm hole diameter is required.

In the future we want to be able to realize even “crazier” shapes and patterns with new equipment and plants. After all, the most beautiful thing about ornamented panels is the diversity of patterns and images that make the building claddings come to life.

Specific Values, Perforations

- Drill radius: 6 or 8 mm
- Punch radius: min. 3 mm, bevel 1.5 mm
- Distance: min. 12 mm
- Edge: min. 50 mm



Pascal Zürn
Foreman of panel
fabrication
and finishing



After the cutting, a lot of handwork is required: the edges are broken with the help of a special planer, extra cutting remains are removed with a sponge, and in the end, the fine fibers are burned off and cleaned, and finally, the edges are water-proofed.

Though normally used as a translucent layer screening glazed sections of multi-layered façades, perforated walls can also serve as stand-alone elements enclosing non-insulated structures, such as parking garages, bus shelters, and open pavilions. Indeed, it is arguably in such special cases where they most closely resemble their traditional purpose as low-tech air-conditioning devices in southern climates.

The following three schemes incorporate perforated walls in connection with fire escape routes, although in some cases this basic functionality is extended considerably. At the school in Laas, the stair tower serves solely as a fire exit; yet at the works yard in Basel the egress balcony doubles as an access corridor and at Newport as a sheltered gathering space for school children. Moreover, the perforations differ in terms of their visual prominence. Whilst barely visible in Laas, they are conspicuous at the campus building in Newport, where the cladding's opening ratio is determined by fire safety regulations.

The same applies to the Basel works yard, where the design pattern serves as the core element of a comprehensive design strategy. What unites the three examples is the treatment of secondary elements, such as fire corridors and staircases—otherwise often a mere afterthought—as integral parts of the overall design. Evidently, any scheme that features single-layered panel walls as dividers between publicly accessible spaces calls for a cladding material that offers a consistent look on all sides. It is this specific requirement that makes integrally colored Swisspearl panels particularly suitable for such external applications.



A photograph of a modern school building at dusk. The building features a prominent facade with a perforated metal screen that glows from interior lights. Several palm trees are planted in front of the building. A wide set of stairs leads up to an entrance on the left. In the foreground, there are concrete planters, blue picnic tables, and a tall, modern light pole. The sky is a deep blue, and the overall atmosphere is serene and contemporary.

EXTERNAL APPLICATIONS
LOOKING DEEP AND CORPOREAL
OR DISSOLVING

WORKS YARD, SWITZERLAND
ELEMENTARY SCHOOL, ITALY
CORONA DEL MAR MIDDLE SCHOOL ENCLAVE, USA



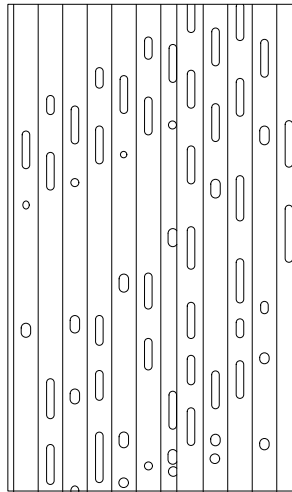

WORKS YARD, BASEL, SWITZERLAND

LOCATION: Brennerstrasse 11 CLIENT: Immobilien Basel-Stadt (on behalf of the City of Basel)

ARCHITECT: Weberbuess Architekten, Basel BUILDING PERIOD: 2013 FAÇADE CONTRACTOR: Stamm Bau AG, Arlesheim, Switzerland

FAÇADE MATERIAL: Swisspearl® ONDAPRESS-36, NATURA Vulcanit N 6326

This works yard for the municipal cleaning and gardening departments of Basel is located on a residual triangular plot wedged between sports grounds, a youth center, and a public park. Incorporating existing perimeter walls and a building that houses staff recreation and administration rooms, the facility comprises four new timber structures clad in white corrugated fiber cement panels. Three of these are single-story garages; the main building holds parking space and workshops on the first floor, and locker rooms, showers and an installations room on the second floor.

The need to provide an upper-level fire escape corridor inspired a façade design that counters the low-key industrial look of the facility and advertises its public function. To guarantee sufficient smoke extraction, the building insurer stipulated a 5 percent open-

ing ratio for the enclosing Swisspearl paneling. Intent on maintaining the integrity of the overall wall surface, architects Weberbuess opted for a perforated façade and commissioned local artist Michel Pfister, who used a ball made of bent wooden slats as the basis for his sketch design. The precise placement of each perforation was key to creating a continuously changing façade picture as the troughs of vertically aligned corrugated panels become invisible when moving sideward. Moreover, by varying the width and length of the slits, the design team managed to create a shaded pattern, thus giving a sense of depth to the wall surface. Modified in dimension and orientation, the same pattern was applied throughout the complex, producing a versatile, yet coherent image for the facility as a whole.

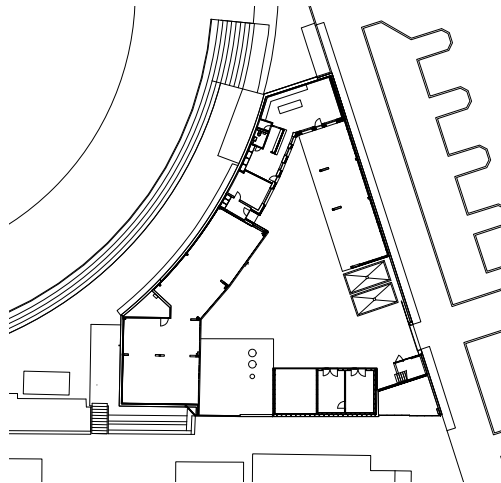

First floor 1:1000

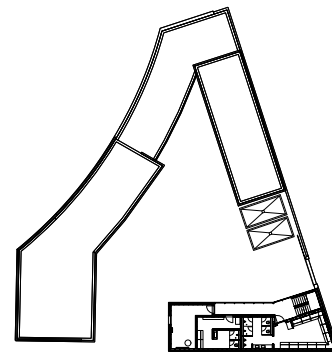

Second floor

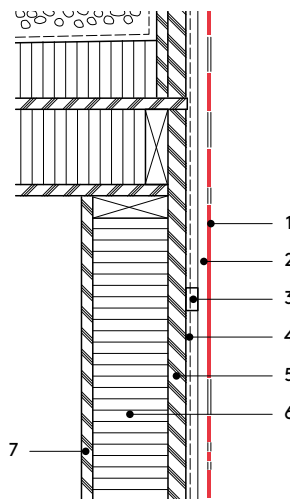
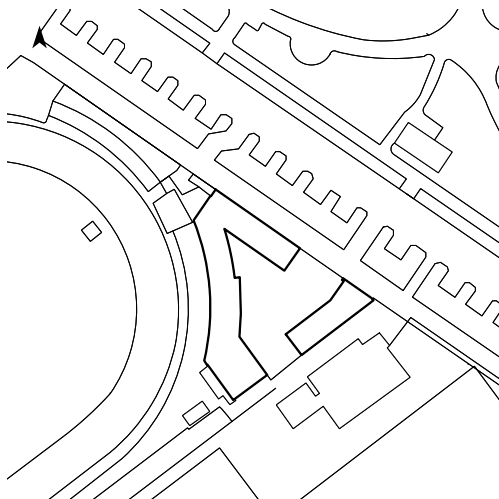

Vertical section 1:20

- 1 Swisspearl® ONDAPRESS-36 corrugated panel 6 mm, perforated
- 2 ventilation cavity
- 3 horizontal sub framing
- 4 moisture barrier
- 5 soft fiber board
- 6 thermal insulation, mineral wool
- 7 plywood board





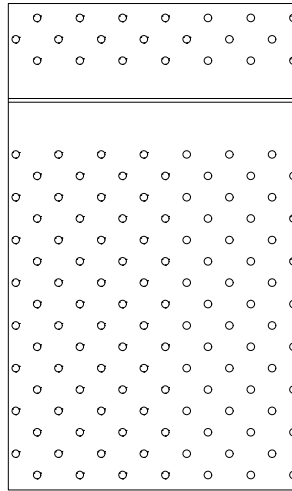

ELEMENTARY SCHOOL, LAAS, ITALY

LOCATION: Schulweg 8 CLIENT: Municipality of Laas ARCHITECT: S.O.F.A., Vienna (Andreas Grasser, Kurt Rauch)
 BUILDING PERIOD: 2014 GENERAL CONTRACTOR AND FAÇADE CONTRACTOR: Unionbau GmbH, Sand in Taufers, Italy
 FAÇADE MATERIAL: Swisspearl® LARGO, PLANEA White P113 and Green P517

Austrian architects S.O.F.A. prevailed over one hundred international competitors with their scheme for a combined kindergarten and school complex for the municipality of Laas in northern Italy. The designers divided the spatial program into two individual buildings, adopting the scale of the neighboring houses while using the existing topography of the site to create differentiated outside spaces for each age group. Complementing the kindergarten, which was completed in 2009, the state-of-the-art elementary school accommodates ten classrooms on the two upper floors as well as a canteen at ground level and an assembly hall with separate access in the basement.

In contrast to the timber-clad kindergarten, the new school is wrapped in pristine

white Swisspearl panels interspersed with light green color accents. Chosen for its longevity, color fastness, and sustainable production credentials, the Swisspearl cladding extends to the adjoining external stair tower, which provides a fire escape route for the upper floor spaces. The paneling of this annex is punctured by a mesh-like pattern of myriad small dot holes, which allow a degree of transparency while sheltering users from wind and precipitation. Beyond this narrow functional purpose, using a perforated cladding allowed the architects to enclose large sections of the open staircase, giving it a distinct sculptural quality in keeping with the equally angled, trapezoid shape of the main structure.

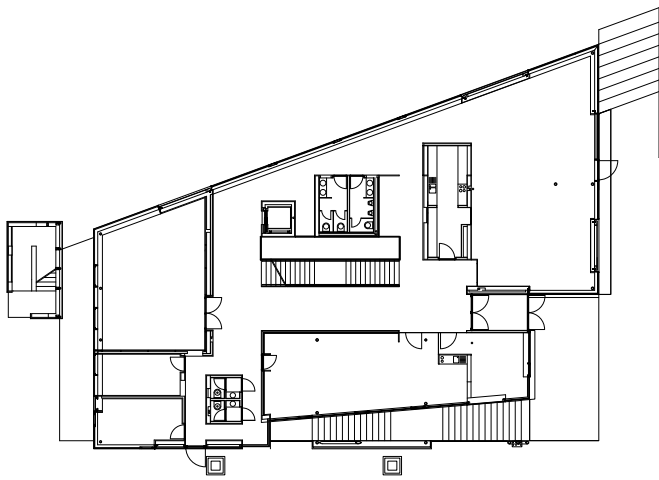

First floor 1:500

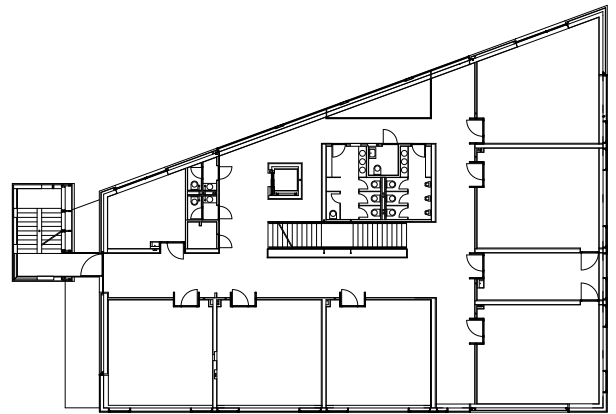

Second floor

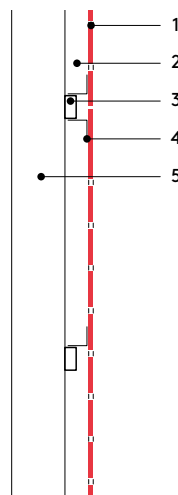

Vertical section 1:20

- 1 Swisspearl® LARGO panel 12 mm, perforated
- 2 ventilation cavity
- 3 horizontal steel profile
- 4 bracket
- 5 steel column

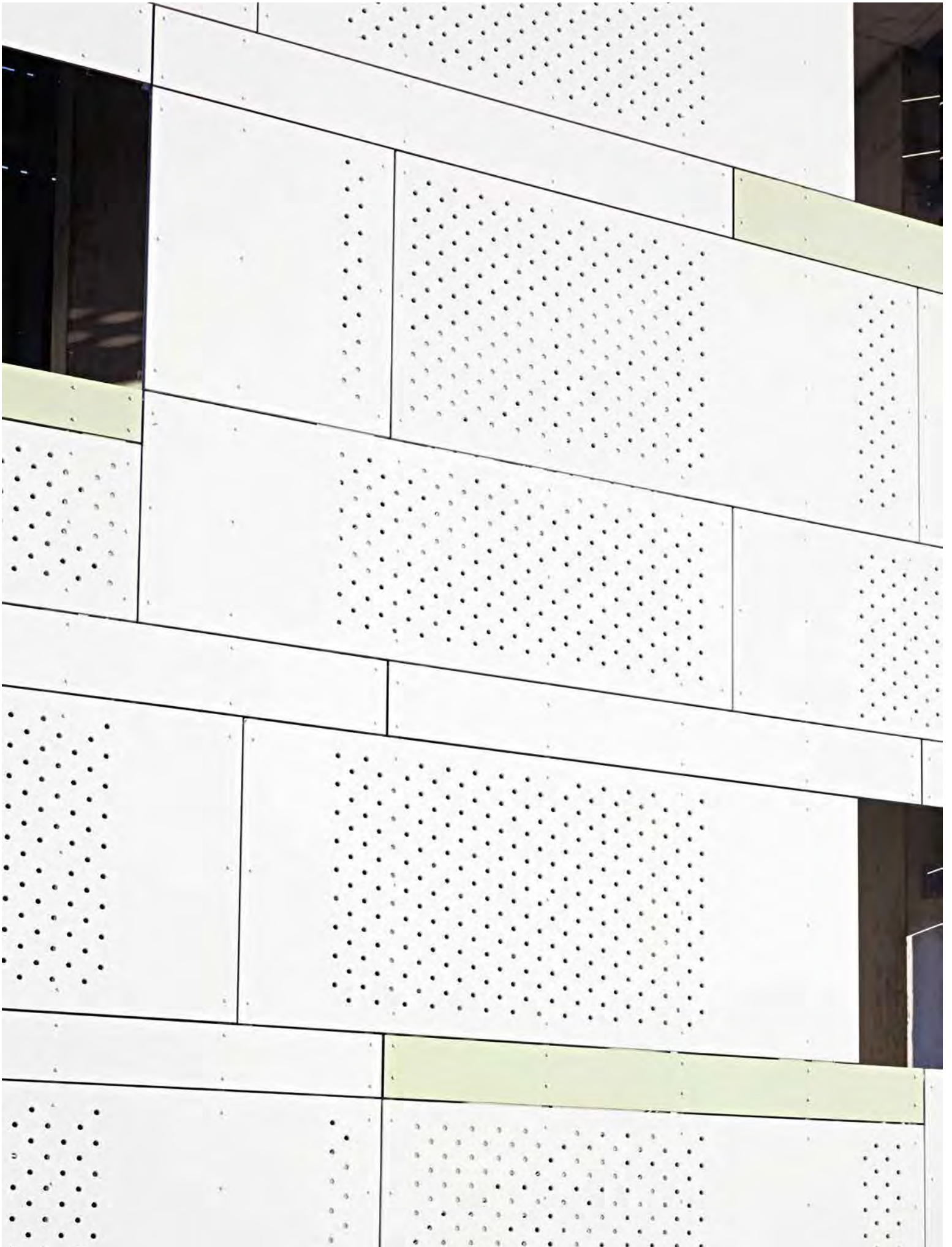



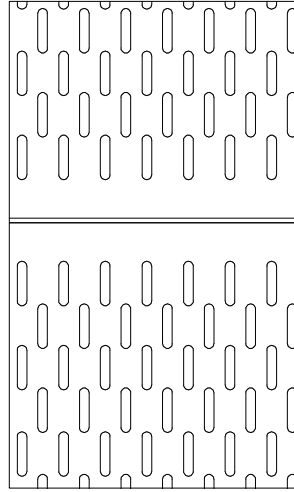

CORONA DEL MAR MIDDLE SCHOOL ENCLAVE, NEWPORT BEACH, USA

LOCATION: 2101 Eastbluff Drive

CLIENT: Newport-Mesa Unified School District ARCHITECT: Dougherty & Dougherty, Costa Mesa (CA)

BUILDING PERIOD: 2012/13 FAÇADE CONTRACTOR: Cal Pac Sheet Metal Inc., Santa Ana (CA)

FAÇADE MATERIAL: Swisspearl® LARGO, CARAT Azurite 7043 and XPRESSIV Yellow 8080

This new high-tech facility complements an existing school complex in Newport Beach, California, providing additional classrooms, science labs, and lecture space and creating a much-needed sheltered enclave for middle-school students within the high-school campus. Designed by Dougherty & Dougherty Architects, the staggered, three-story building encloses a landscaped courtyard from which a number of interconnected staircases, ramps, and access corridors lead to the various facilities in the form of a promenade architecturale.

An integral part of a comprehensive sustainability strategy aimed at LEED Gold certification, the architects devised a rain screen façade clad in Swisspearl panels, which will boost the building's energy performance and help keep long-term maintenance costs to a minimum. Though adopting the geometrical clarity and rectangularity of the mid-century

campus, the new facility contrasts sharply with the texture and color scheme of the existing brick structures by displaying a combination of exposed steel columns, smooth concrete surfaces, and Swisspearl paneling. Large sections of the cladding on the two upper levels feature a chessboard pattern of perforations, softening the monolithic appearance of the building by day whilst dissolving it almost entirely when backlit at night. The perforations were chosen for functional as well as aesthetic reasons. For one, they allow sufficient airflow into the enclosed spaces to comply with local building code requirements for non-fire rated external egress balconies. More importantly, they mark out a series of sheltered gathering zones along the circulation route, animated by a continuously shifting shading pattern and maintaining a visual connection to the central courtyard at the heart of the enclave.

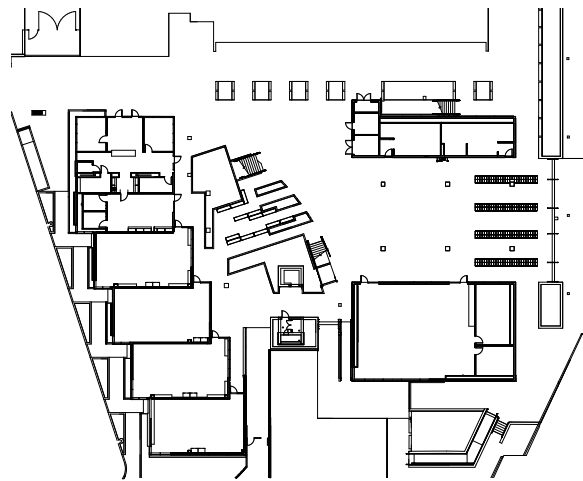

First floor 1:1000

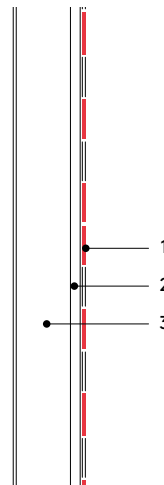
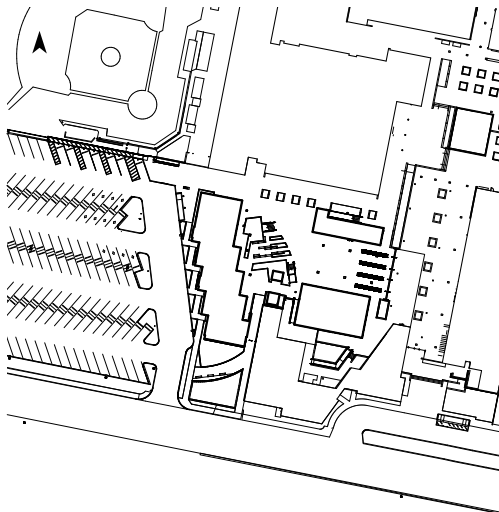

Vertical section 1:20

- 1 Swisspearl® LARGO panel 12 mm, perforated
- 2 ventilation cavity, vertical panel support profile
- 3 steel beam

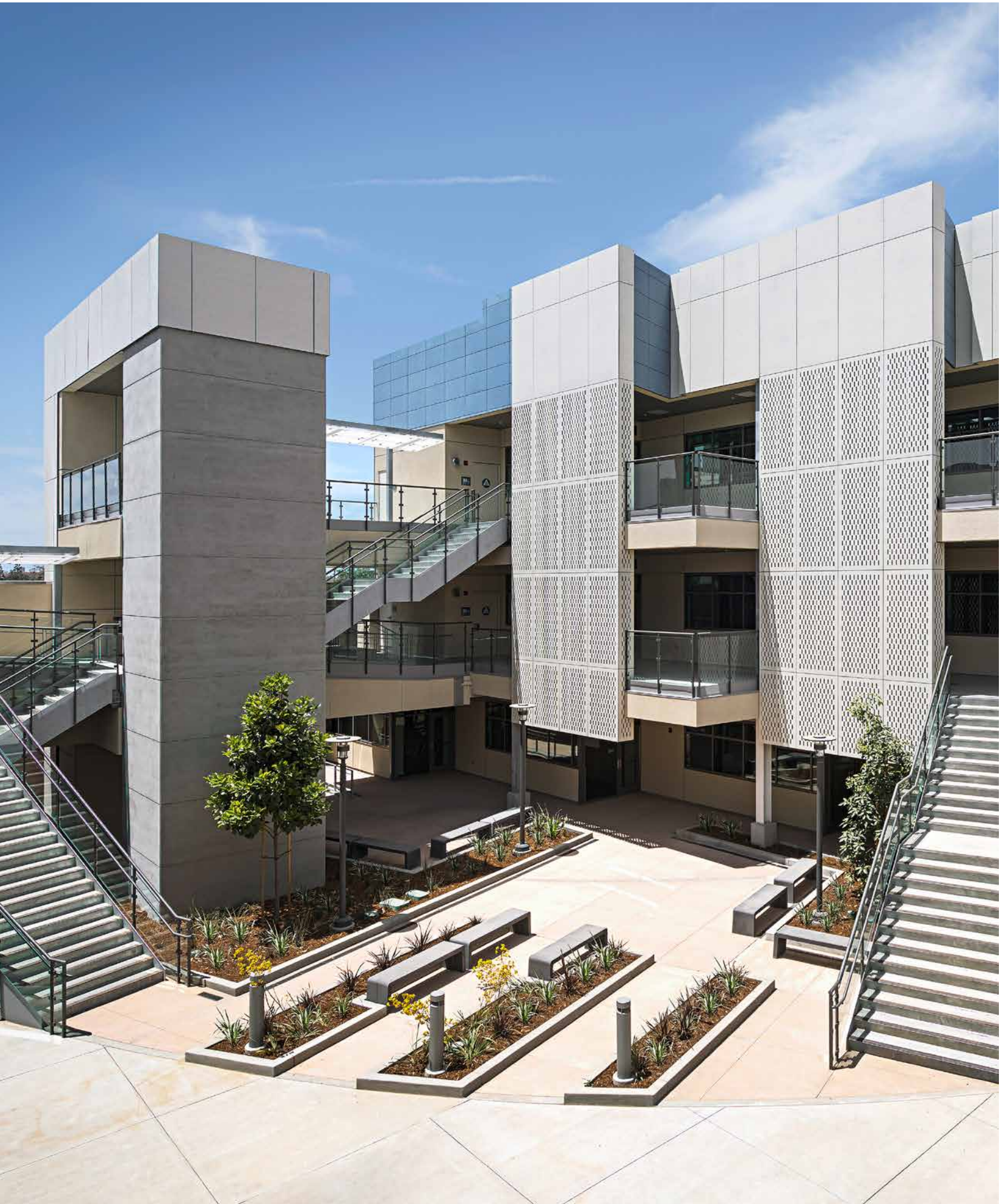

In the majority of cases perforations are utilized as part of a broader design concept and are limited to specific façade elements or specific sections of a larger scheme. Though they can have a distinct visual effect, their main purpose is functional rather than aesthetic. They serve to illuminate and ventilate specific rooms while providing a degree of privacy and visual cover—in other words, they perform the traditional role of shuttered or louvered windows, without, however, affecting the coherence and integrity of the façade.

The following examples illustrate the wide range of such subordinate applications. At one end of the spectrum is the factory conversion at Aathal, where perforations are used sparingly and inconspicuously to screen a small number of existing wall openings behind the dark corrugated cladding. At the guesthouse in Willisau, punctured panels are used for bathrooms and ancillary spaces only, but the white color of the cladding makes them a rather more prominent feature of the façade composition.

The use of sliding perforated screens at the apartment block in Locarno is likewise limited to specific spatial units—in this case bedrooms rather than bathrooms—but together they cover a much larger area and therefore have a profound and permanently changing impact on the look of the building. Similarly, the perforations at the educational complex in Zagreb, which illuminate and activate a number of circulation and service spaces, cover almost the entire wall surface. In spite of this, their visual impact is deliberately muted to enhance the contrast between open and closed frontages.

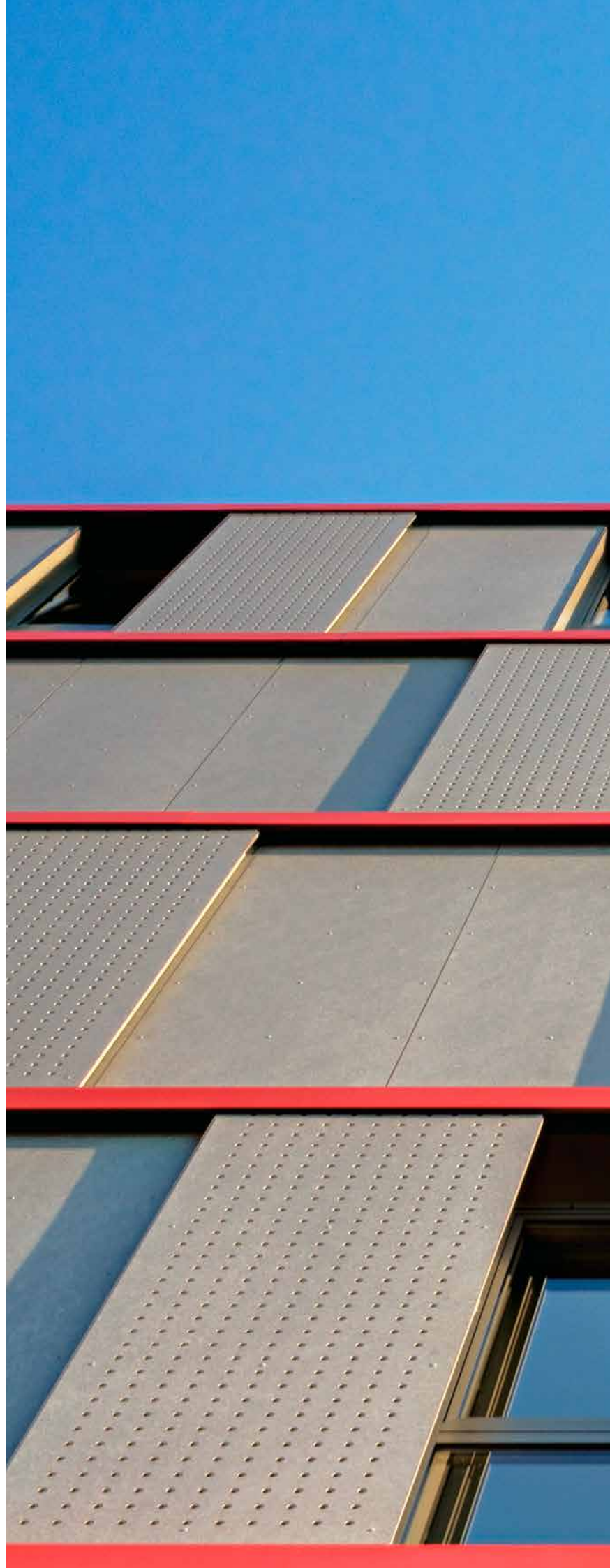

PARTIAL APPLICATIONS

PROTECTING FROM FIRE, SUN, AND INQUISITIVE GAZES

COMMERCIAL AND OFFICE BUILDING, SWITZERLAND
"GASTHAUS POST" EXTENSION, SWITZERLAND
ORIZIA APARTMENT BLOCK, SWITZERLAND
EDUCATIONAL COMPLEX KAJZERICA, CROATIA

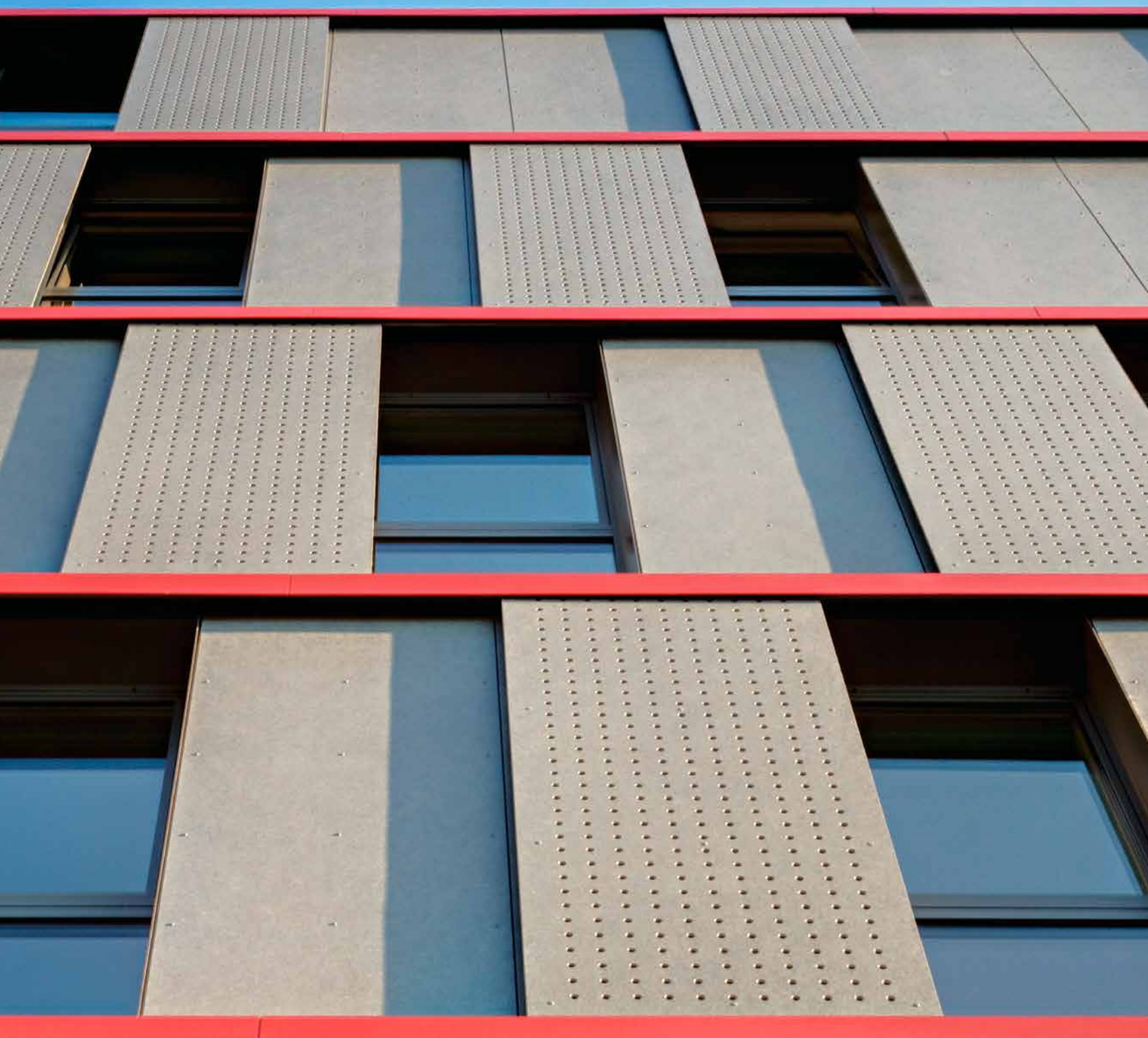

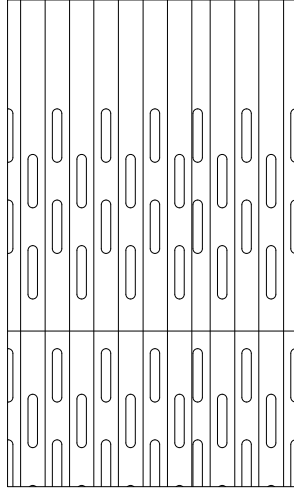

COMMERCIAL AND OFFICE BUILDING HIAG, AATHAL-SEEGRÄBEN, SWITZERLAND

LOCATION: Zürichstrasse 22 CLIENT: HIAG Immobilien AG, Zurich

ARCHITECT: OOS Architekten, Zurich BUILDING PERIOD: 2013 FAÇADE CONTRACTOR: Husner AG, Frick

FAÇADE MATERIAL: Swisspearl® ONDAPRESS-36, NATURA Vulcanit N 6512

In 2010 property developer Hiag acquired Streiff, once a major cotton manufacturer, with a view to revitalizing its substantial real estate portfolio. Serving as a two-stage light-house scheme for this undertaking, the company's premises in Oberaathal, on the periphery of Zurich, have been transformed into a mixed-use office and retail complex. Linked by a fully glazed vestibule to the old, heritage-protected spinning mill (which has been converted into office lofts, shops, and a restaurant), this second, more recent structure provides 4,000 square meters of retail space spread over two floors complete with storage and parking facilities in the basement.

Zurich-based OOS Architects combined precast gray concrete base elements and anthracite-colored corrugated Swisspearl panels to create a unified and deliberately

utilitarian look in keeping with the building's industrial past. Arranged with a series of overlaps, the undulating and slightly slanted paneling adds a sense of depth and pronounced horizontal emphasis to the façades, accentuated by the yellow undersides of the projecting parts. The building's designation as a retail park eliminated the need for natural lighting and allowed the architects to wrap the cladding around existing window openings. Rectangular fields of slip-shaped perforations add an unusual iridescent effect and filter a limited, almost negligible amount of light and air into the large interior. Indeed, the chief purpose of the perforations is as an active fire protection measure, as their opening ratio enables the windows to serve as heat and smoke vents.



Ost
Anlieferung



adengeschäften

FREIHALTUNGSPFLICHT

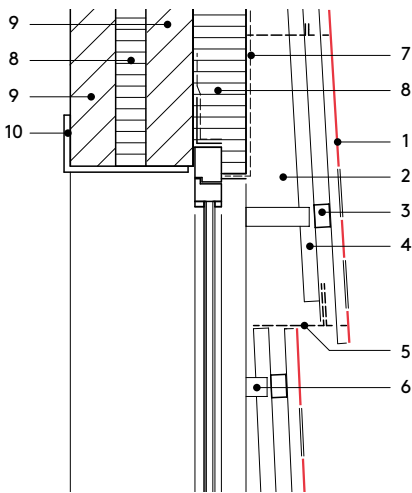

Vertical section 1:20

- 1 Swisspearl® ONDAPRESS-36 corrugated panel 6 mm, perforated
- 2 ventilation cavity
- 3 horizontal sub framing
- 4 vertical sub framing
- 5 insect screen
- 6 bracket
- 7 moisture barrier
- 8 thermal insulation
- 9 brickwork
- 10 window frame

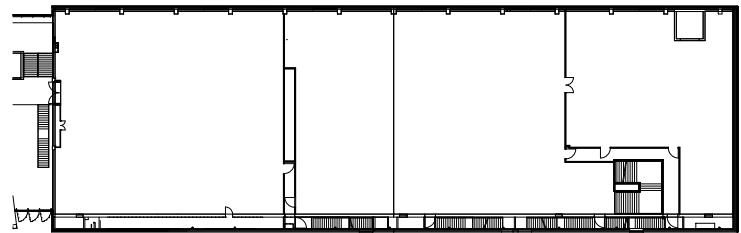

Second floor

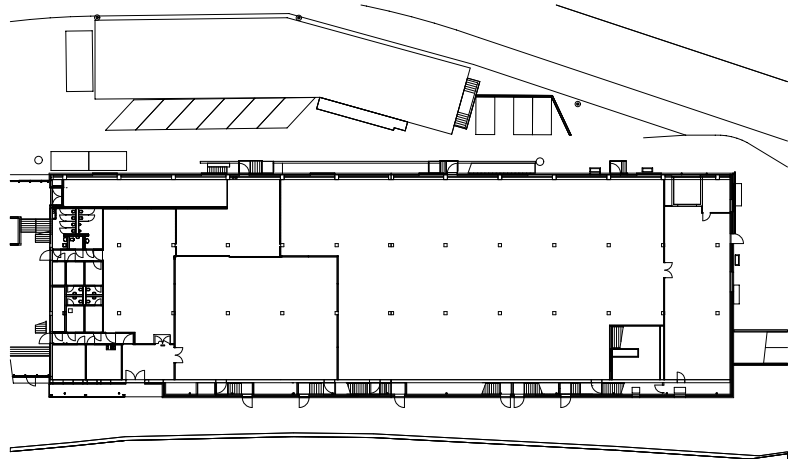

First floor 1:500



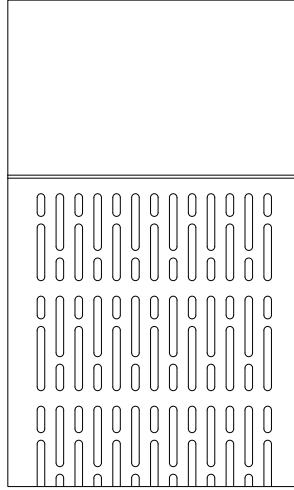

"GASTHAUS POST" EXTENSION, WILLISAU, SWITZERLAND

LOCATION: Leuenplatz 3 CLIENT: Edith und Hans Herzog, Willisau

ARCHITECT: Baureag Architektengruppe AG, Willisau

BUILDING PERIOD: 2010/11 FAÇADE CONTRACTOR: Schürch-Egli AG, Sempach

FAÇADE MATERIAL: Swisspearl® LARGO, CARAT Onyx 7091

Baureag prevailed over three invited competitors with their scheme for a four-story extension to this family-run guesthouse in the small town of Willisau. Linked to the existing building by an entrance lobby, the new annex provides eight hotel rooms on the second floor and two condominiums on each of the two levels above. Responding to its sensitive location on the edge of the historic center, the new building has a crooked plan geometry aligned with the medieval street layout. The north façade sits on top of an existing stream bank wall; the south elevation features a recessed ground floor, which accentuates the main entrance and broadens the adjacent public square.

The architects chose a uniform white Swisspearl cladding, which creates a contrast to the rendered surfaces of the neighboring

structures. Precisely adjusted to the indentations and angles of the envelope, the slightly glossy and carefully detailed paneling adds a restrained, yet unapologetically modern touch to the new extension. The design of the two main façades reflects the orientation and specific urban situation of the building. The south-facing public front combines extensive glazing with continuous, angled balconies, which give it a dynamic, horizontal emphasis. The rear wall, on the other hand, has a more sober appearance owing to the balanced distribution of windows and cladding, complete with a number of ceiling-high perforated Swisspearl panels. Shielding the hotel bathrooms from views, the punctured screens exhibit an elegant pattern of vertical slits in two lengths, lending visual interest to the façade without affecting its serenity.



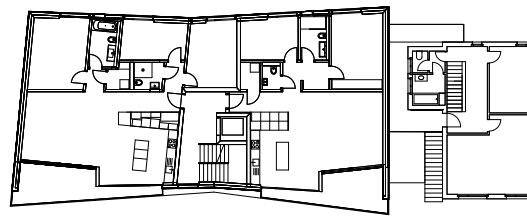

Second floor

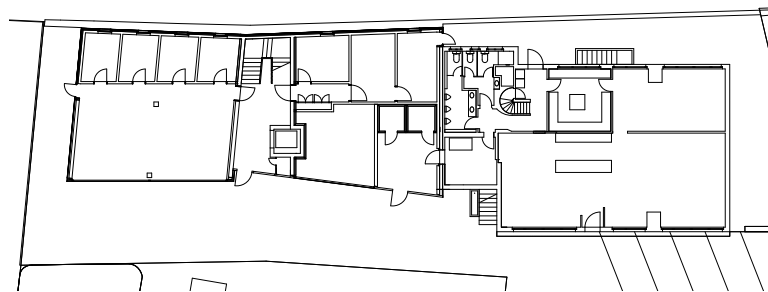

First floor 1:500

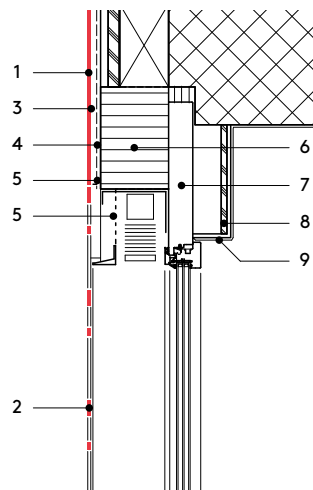
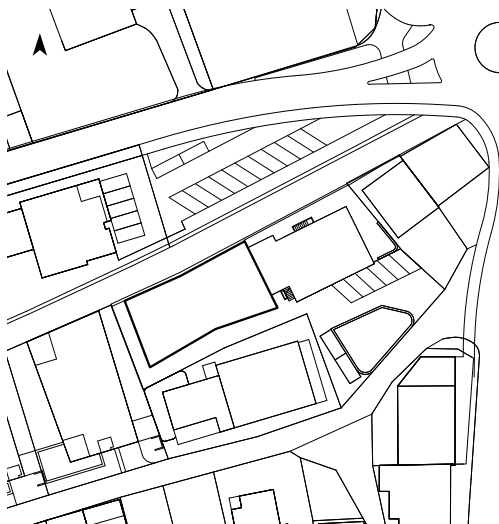

Vertical section 1:20

- 1 Swisspearl® LARGO panel 8 mm
- 2 Swisspearl® LARGO panel 8 mm, perforated
- 3 ventilation cavity, vertical sub framing
- 4 moisture barrier
- 5 insect screen
- 6 thermal insulation, mineral wool
- 7 window frame
- 8 gypsum plaster board
- 9 fine plaster



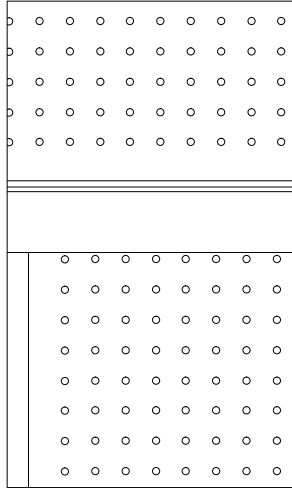

ORIZIA APARTMENT BLOCK, LOCARNO, SWITZERLAND

LOCATION: Via Serafino Balestra 42 CLIENT: Municipality of Locarno
 ARCHITECT: Moro e Moro, Locarno (Franco Moro) BUILDING PERIOD: 2006–2009
 FAÇADE CONTRACTOR: Laube SA, Biasca
 FAÇADE MATERIAL: Swisspearl® LARGO, XPRESSIV Grey 8060

This five-story apartment block in the Swiss city of Locarno is the outcome of a national competition won by local architects Moro e Moro in 2006. The uncompromising slab sits amongst a disordered cluster of speculative housing schemes, adjoining a new tree-planted garden to one side and closing the landscaped courtyard of a neighboring residential estate to the other.

The building rests on an oblique, windowless concrete base containing cellar compartments and other ancillary rooms. Four breezeways cut through this plinth, providing access to an equal number of circulation cores servicing the individual house segments. Offering a degree of flexibility, all apartments feature an open-space arrangement without load-bearing interior walls, divided into south-facing living and dining

areas and north-facing bedroom layers by means of central bathroom units. The design and detailing of the envelope, which is clad in a uniform gray Swisspearl paneling structured by continuous red horizontal bands, supports the fundamental distinction into day and night zones. The fully glazed living areas are recessed behind deep overhanging balconies incorporating mobile awnings to lower the impact of direct sunlight. Preserving the integrity of the remaining façades, all bedroom windows feature perforated sliding screens made of isochromatic Swisspearl panels. The punctured shutters, which cover three quarters of the total wall surface, allow residents to shield their private rooms from intrusive views whilst at the same time benefiting from natural light and the cooling effect of the prevailing northern winds.



42

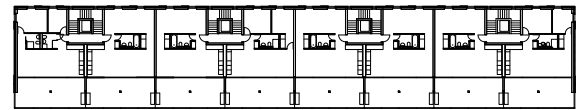
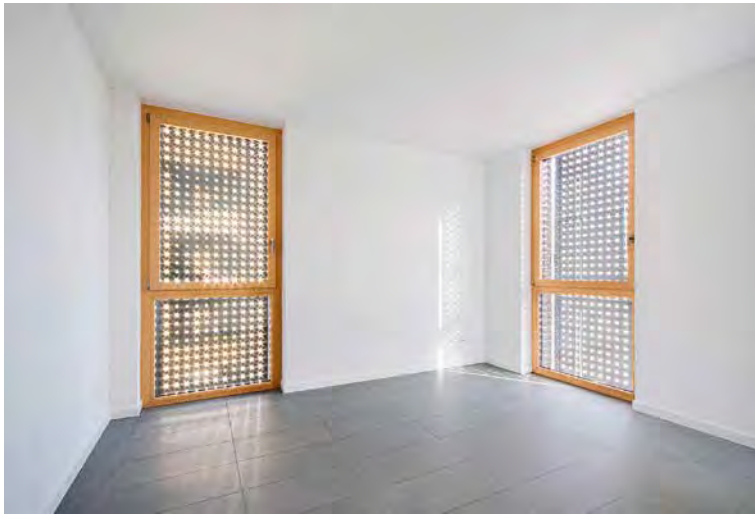

Attic floor

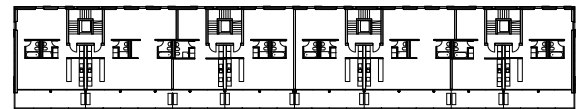

Second floor

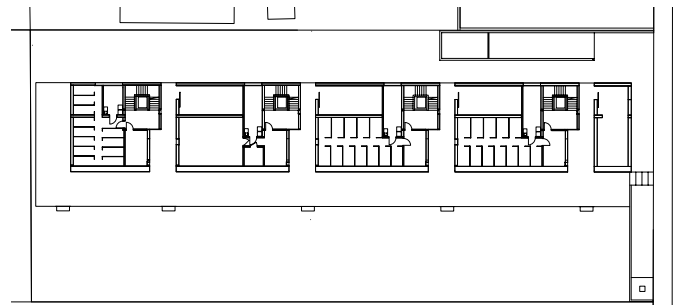

First floor 1:1000

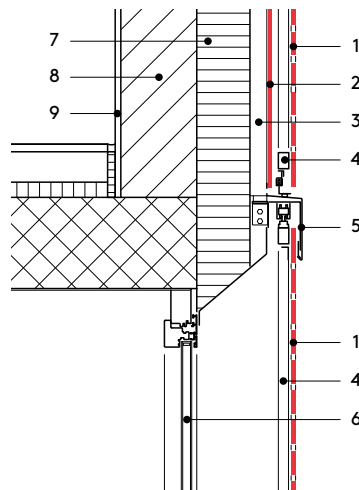

Vertical section 1:20

- 1 Swisspearl® LARGO panel 12 mm, perforated
- 2 Swisspearl® LARGO panel 8 mm
- 3 ventilation cavity
- 4 sub framing
- 5 aluminum sheet
- 6 window timber/aluminum
- 7 thermal insulation
- 8 brickwork
- 9 plaster

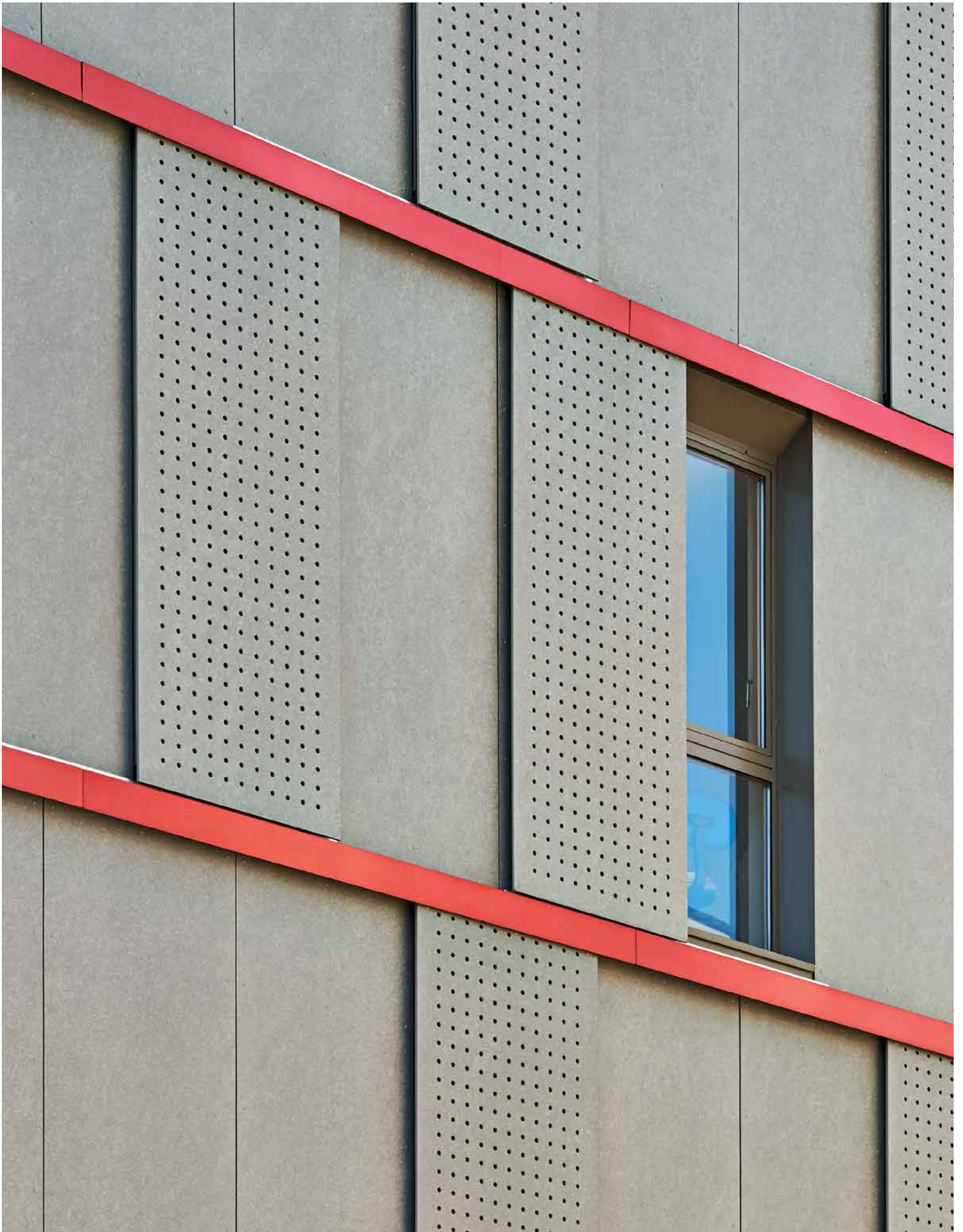

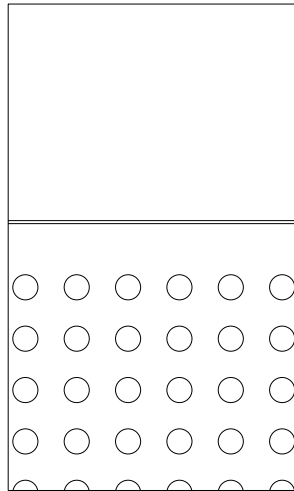

EDUCATIONAL COMPLEX KAJZERICA, ZAGREB, CROATIA

LOCATION: Ulica Žarka Dolinara CLIENT: City of Zagreb ARCHITECT: Sangrad + AVP, Zagreb
(Vedran Pedišić, Erick Velasco Farrera, Hrvoje Davidovski, Mladen Hofmann, Iva Marjančević)
BUILDING PERIOD: 2014 GENERAL CONTRACTOR: Gradnja, Osijek FAÇADE CONTRACTOR: Imal-Plast, Osijek
FAÇADE MATERIAL: Swisspearl® LARGO, CARAT Black Opal 7020 HR

This vast educational complex in the Croatian capital of Zagreb is divided into three functional units arranged along a linear axis. The school at the heart of the facility features three parallel, three-story bars and is complemented by a lower nursery and kindergarten building to the west and a partially subsurface gymnasium to the east. The compact grouping of the three structures frees up a large portion of the site for outdoor facilities, while the classroom slabs are lifted from the ground to create a continuous sheltered gathering and circulation space.

The three buildings share the same scale and geometry and feature common design elements. Apart from exposed concrete pillars and timber ceilings, which metaphorically transform the central schoolyard into an

artificial forest, almost the entire complex is clad in uniform black Swisspearl fiber cement panels accentuated by steel fire escape stairs and numerous timber-framed doors and windows. The spatial conception of the school building inspired the large-scale application of perforated panels. Accessed via lateral corridors, all classrooms are oriented toward the sun and benefit from all-day direct sunlight through extensive glazing. To counterpoint the openness of the south-facing frontages, architect Vedran Pedišić and his collaborators devised entirely windowless rear elevations, punctured by myriad circular perforations, which feed dappled light into the interior and create special visual effects inside corridors, staircases and,—most daringly—lavatories.





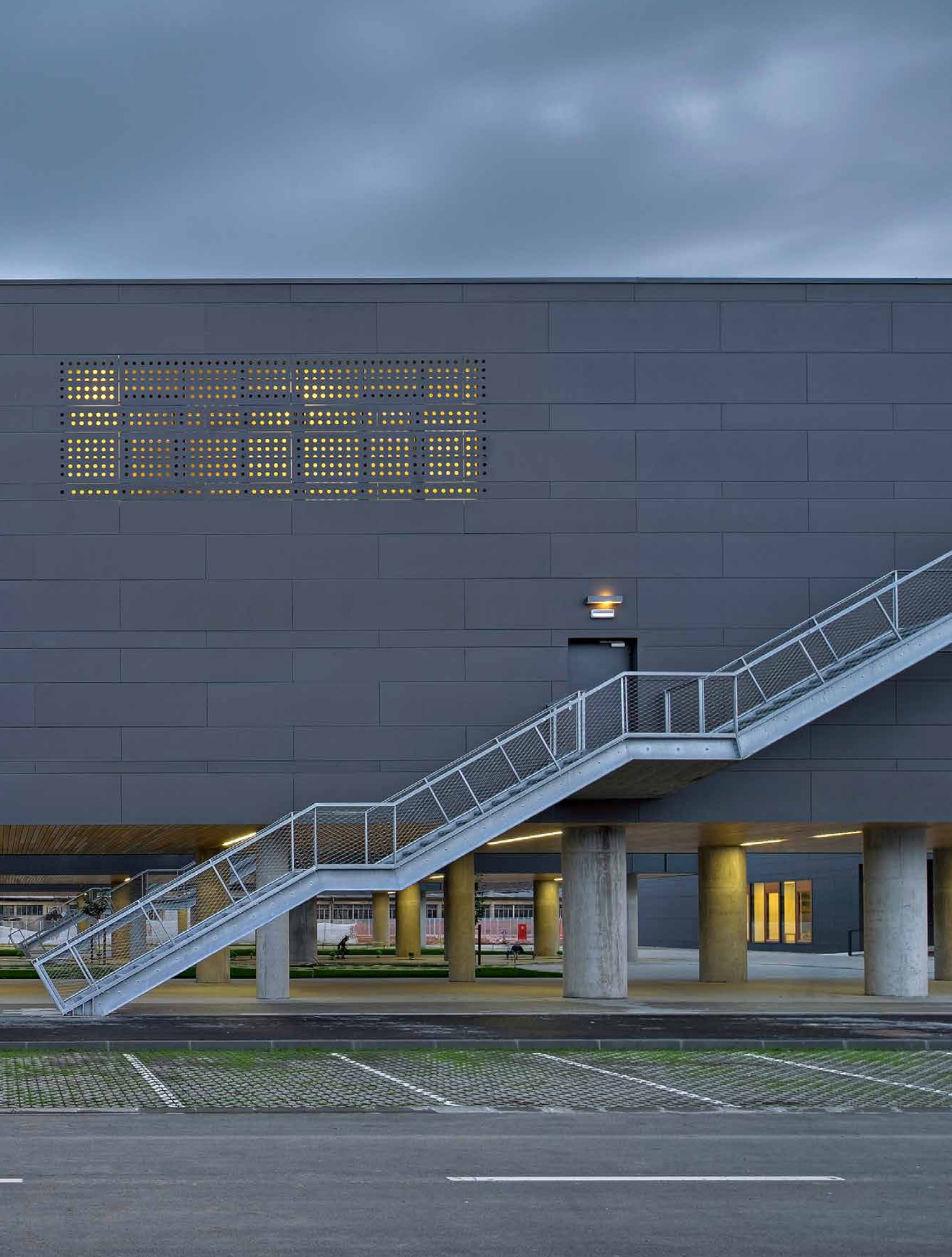

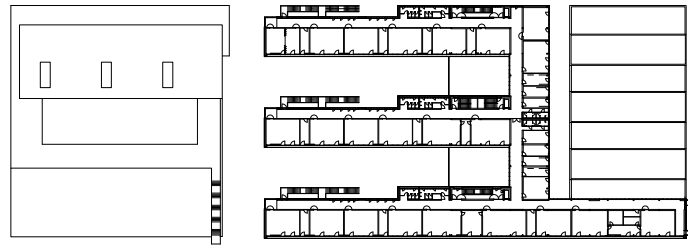

Third floor

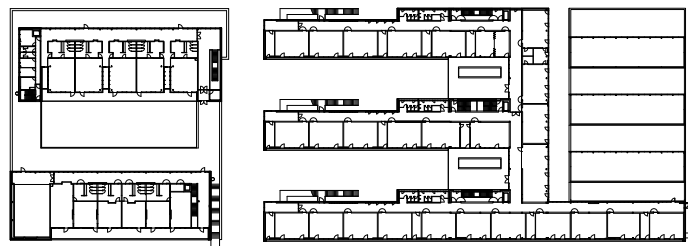

Second floor

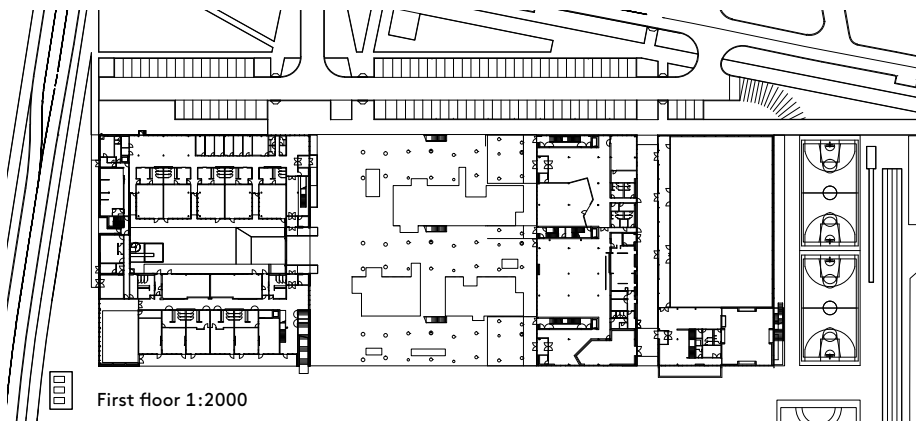

First floor 1:2000

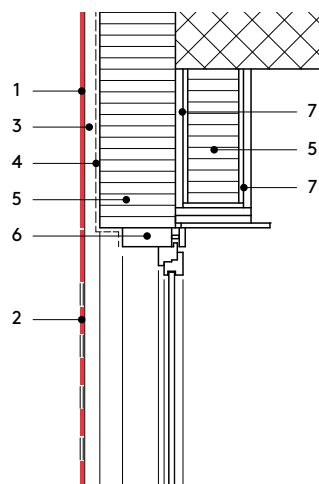
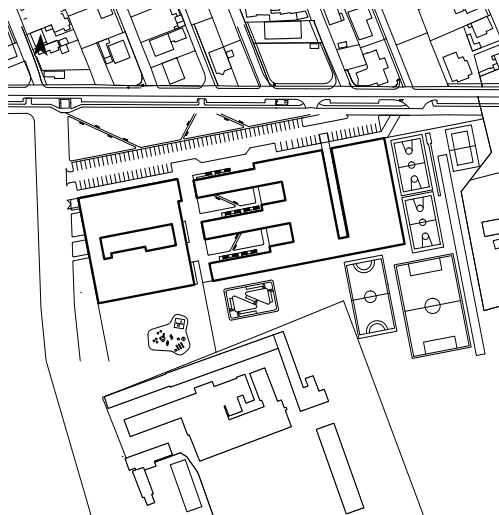

Vertical section 1:20

- 1 Swisspearl® LARGO panel 8 mm
- 2 Swisspearl® LARGO panel 8 mm, perforated
- 3 ventilation cavity, vertical sub framing
- 4 moisture barrier
- 5 thermal insulation
- 6 metal framing
- 7 gypsum plaster board



In contrast to the preceding examples, the buildings in this section showcase perforated panels as their primary design feature. Though they serve for illumination and ventilation purposes as well, these appear to be secondary as the main consideration is clearly an aesthetic one. With means of expression limited solely by the creativity of the architect, it is all but impossible to identify common characteristics. In general, however, the perforations are employed in a comprehensive and striking manner, which tends to have a disintegrating, almost dematerializing effect on the overall wall surface.

A prime example is the office building in Cartaxo, whose cladding features an all-encompassing perforation pattern incorporating the company's logotype. Equally eye-catching, if slightly less literal, is the façade design of a church in Budapest, where the architects reproduced a traditional embroidery pattern to give a sense of place to the new parsonage. At the University building in Springfield, the perforations support a gradual increase in transparency from rear to front while giving added visual interest to the show-stopping entrance canopy of the student welcome center.

The kindergarten at Cervenjak takes a special position in that the design pattern results from gaps between the panels rather than from perforations in the narrower sense. Tellingly, it is the only building illustrated in this issue of "Swisspearl Architecture" where the façade ornamentation is indeed purely decorative and serves no functional purpose whatsoever.



PRIMARY APPLICATIONS

DECORATING WITH A LOGO, EMBROIDERY, OR BIRD SILHOUETTE

OFFICE BUILDING TAGUS GÁS, PORTUGAL
PARSONAGE, PARISH CHURCH OF THE CELESTIAL QUEEN, HUNGARY
MSU DAVIS-HARRINGTON WELCOME CENTER, MISSOURI STATE UNIVERSITY, USA
KINDERGARTEN, SLOVENIA



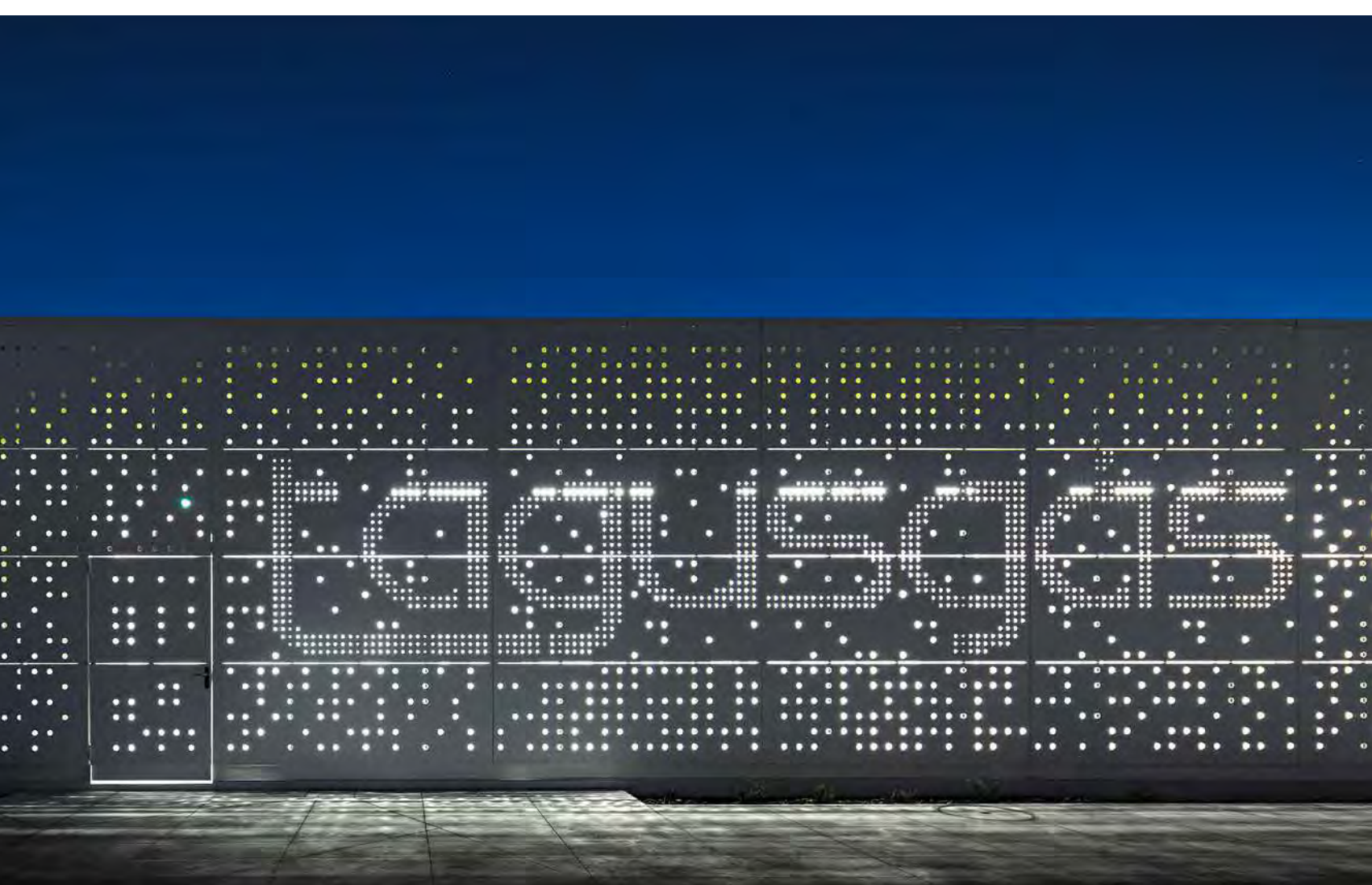

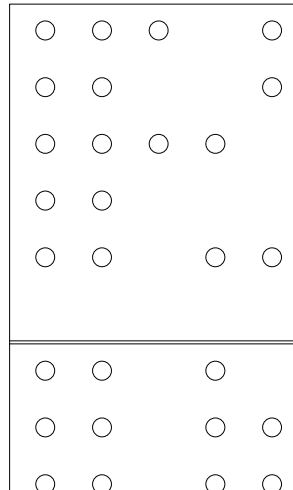

OFFICE BUILDING TAGUS GÁS, CARTAXO, PORTUGAL

LOCATION: Parque de Negócios do Cartaxo CLIENT: Tagus Gás, Cartaxo

ARCHITECT: Saraiva & Associados, Lisbon (Miguel Saraiva, Lara Gomes, Bruno Pereira) BUILDING PERIOD: 2012–2014

GENERAL CONTRACTOR: Lena Construções, SA, Santa Catarina da Serra, Leiria

FAÇADE CONTRACTOR: Sotecnisol, Revestimentos, Lisbon FAÇADE MATERIAL: Swisspearl® LARGO, CARAT Onyx 7099

This new headquarters for Tagus Gás in Cartaxo, fifty miles from the Portuguese capital, is the country's first office building to receive BREEAM certification. Designed by international practice Saraiva & Associados in partnership with consultants Ecochoice, the structure features an array of sustainability measures aimed at reducing its environmental impact and optimizing its energy efficiency.

The envelope is a core element of this sustainability strategy, which covers the building's entire life cycle—from manufacturing and construction to utilization and post-occupancy. The façade system features extensive high-performance glazing veiled by a perforated skin made of sustainably produced and recyclable Swisspearl panels. Dotted by countless circular holes, the cladding

helps minimize energy consumption by letting plenty of natural light penetrate the building. At the same time, it screens a number of manually operable windows, which allow the interiors to be naturally ventilated, improving air quality and comfort levels while significantly reducing expenditures for air-conditioning units. Beyond its practical benefits, the punctured cladding serves a major aesthetic purpose. Inconspicuous during the day, the myriad perforations create a striking display when the interior is fully lit, conferring a glowing, almost dematerializing effect to the façades. Moreover, the perforation pattern incorporates the company logo, thus advertising the brand to the nearby A1 highway, which connects Lisbon and Porto, the country's most populous cities.

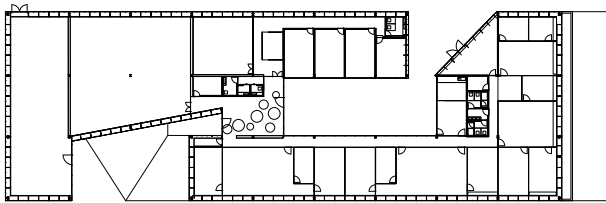

First floor 1:1000

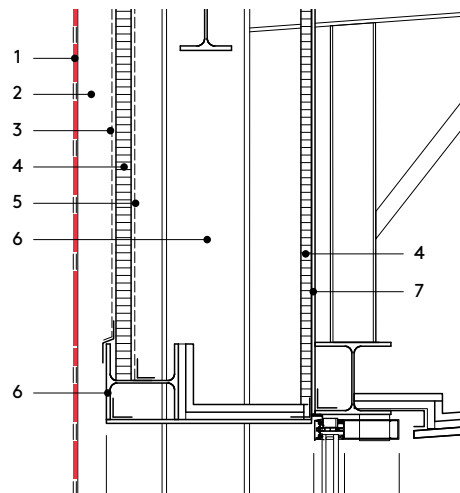
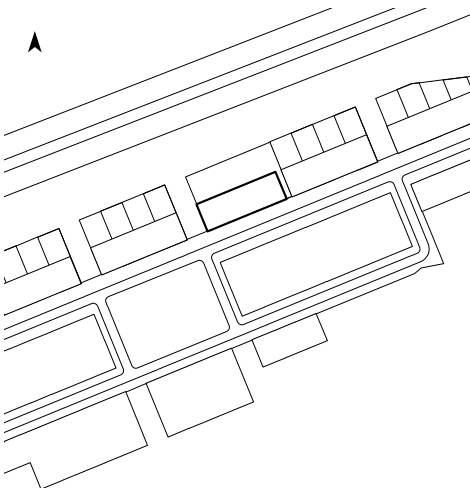

Vertical section 1:20

- 1 Swisspearl® LARGO panel 8 mm, perforated
- 2 ventilation cavity, vertical sub framing
- 3 moisture barrier
- 4 thermal insulation
- 5 vapor retarder
- 6 steel beam
- 7 metal sheet





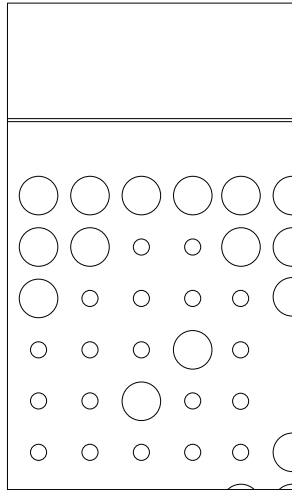

PARSONAGE PARISH CHURCH OF THE CELESTIAL QUEEN, BUDAPEST, HUNGARY

LOCATION: Szent István square CLIENT: Parish Church of the Celestial Queen

ARCHITECT: 4 plusz Építész Stúdió (Zoltán Berzsák), Budapest BUILDING PERIOD: 2015 GENERAL CONTRACTOR: Kharisz Kft., Veszprém
FAÇADE CONTRACTOR: Evolution Kft., Budapest FAÇADE MATERIAL: Swisspearl® LARGO, CARAT Onyx 7090

Located at the heart of the Hungarian capital, this former music school has been converted into a new home for the Parish Church of the Celestial Queen. The scheme involved a careful restoration of the dilapidated historical building, which now accommodates the traditional functions of the parsonage, such as the parson's quarters, a classroom for religious education, the library, the banquet hall, and a visitor's apartment. In addition, architects 4 plusz designed a new and decidedly modern structure that connects the two lateral wings of the existing U-shaped building and divides the garden space into two distinct courtyards. Fully glazed to either side, the transparent ground floor of the extension provides space for social events and opens a vista from the reception area to the rear garden.

Lending a unified appearance to the new structure, the architects clad the pitched roof, both external walls, and a number of perforated shutters in Swisspearl panels, choosing a light color scheme in keeping with the white stucco of the existing building. The upper level of the new wing holds a more enclosed and intimate assembly room shrouded by punctured panel screens that can, in part, be opened. The extensive perforation pattern consists of numerous circular holes of varying diameter and mitigates the strict symmetry of the composition. Inspired by traditional Hungarian embroidery, the façade ornamentation evokes a sense of place and enhances the open and public nature of the new parsonage.

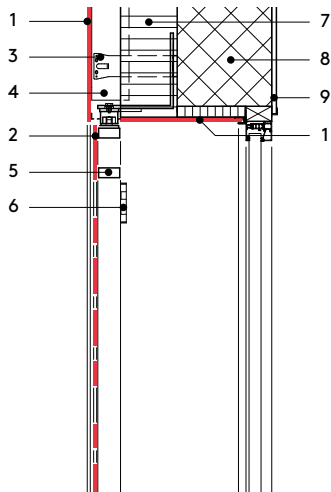
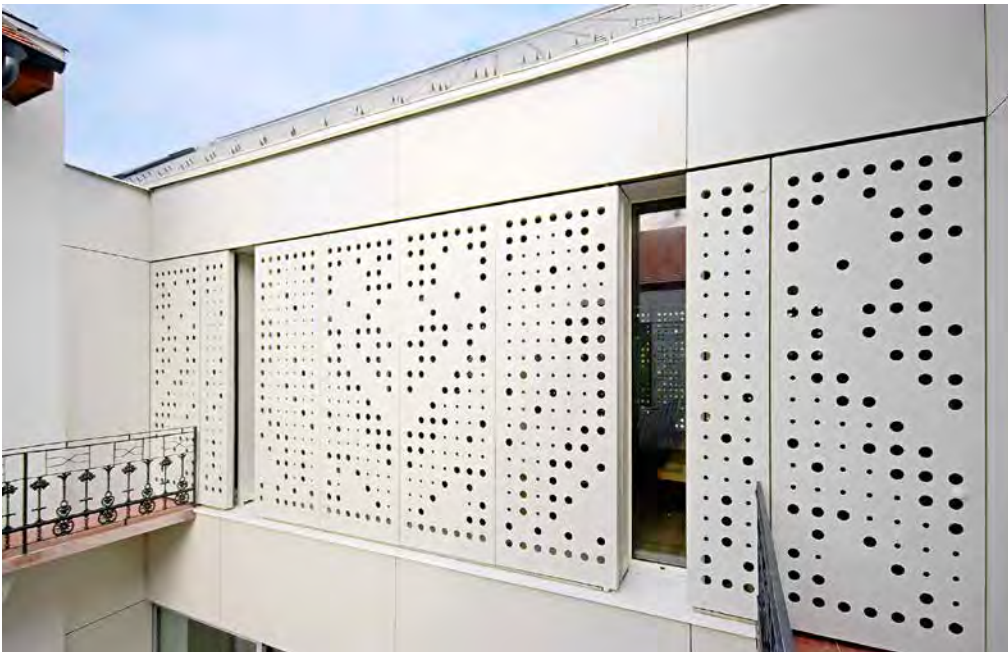

Vertical section 1:20

- 1 Swisspearl® LARGO panel 8 mm
- 2 Swisspearl® LARGO panel 8 mm, perforated
- 3 bracket
- 4 ventilation cavity, vertical sub framing
- 5 sub framing
- 6 hinge
- 7 thermal insulation
- 8 concrete
- 9 gypsum board

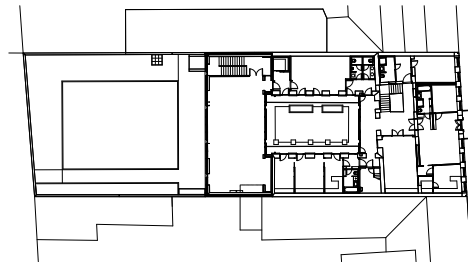

Second floor

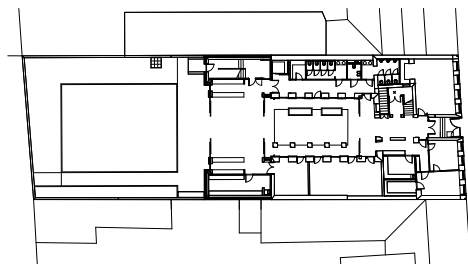
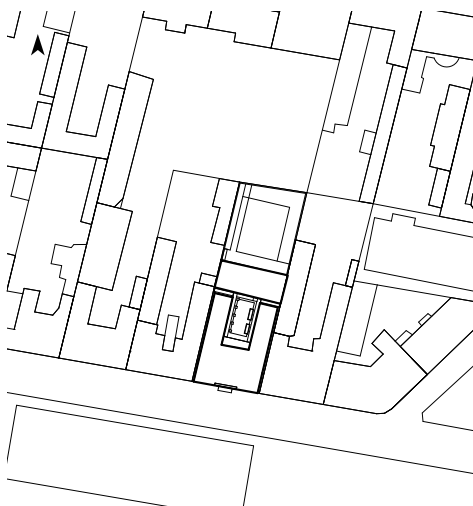

First floor 1:1000





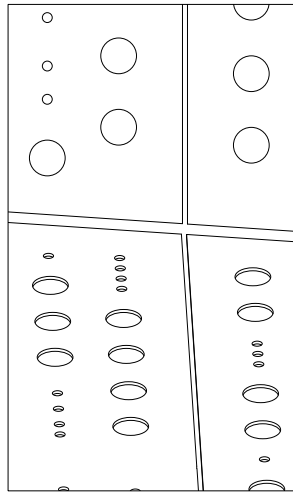

MSU DAVIS-HARRINGTON WELCOME CENTER MISSOURI STATE UNIVERSITY, SPRINGFIELD, USA

LOCATION: 901S National Ave CLIENT: Missouri State University ARCHITECT: Dake Wells Architecture, Springfield
 BUILDING PERIOD: 2014/15 GENERAL CONTRACTOR: Wright Construction Services, St Peters (MO)
 FAÇADE CONTRACTOR: Loveall Custom Sheet Metal, Springfield FAÇADE MATERIAL: Swisspearl® LARGO, CARAT Onyx 7090

Missouri State University entrusted local practice Dake Wells Architecture with the design of this new welcome center, which serves as a front gate to its Springfield campus. Conceived as a signature building for the institution as a whole, the five million dollar, 13,000-square-foot facility doubles as a multi-purpose venue for special events and a gathering place for visitors and prospective students. Enhancing the building's visual presence, the architects devised a monumental two-story scheme that allows for a future expansion incorporating existing admissions and registration services. In addition to the spacious entrance lobby, the ground floor accommodates public functions, such as the hundred-seat auditorium and a small catering kitchen; administrative offices and conference rooms are located on the upper level and are accessed via a suspended walkway.

The building enclosure combines a variety of materials in response to the surrounding campus context. The rear ground-floor spaces are largely concealed behind limestone cladding; to the north, the envelope increases in transparency, culminating in a tapering glass curtain wall that accentuates the building's main entrance. The architects used a seemingly paper-thin layer of white Swisspearl panels to sheathe the fully glazed upper sections of the east and west façades. The latter extends slightly beyond the pointed corner of the building where the lower part folds slightly away to extend a welcoming gesture to visitors. Inspired by the pattern of a composition booklet, a seemingly random arrangement of circular perforations feeds dappled light into the atrium and allows views from the second-floor walkway.



TER



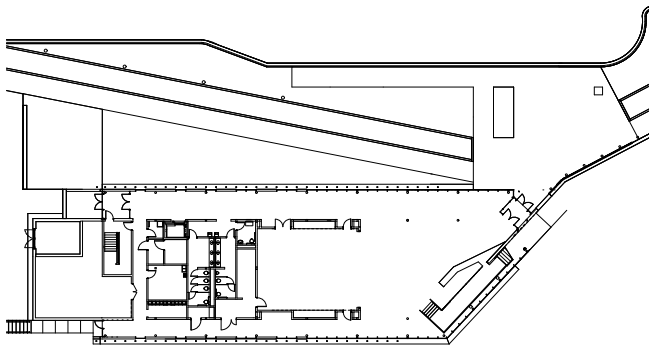

First floor 1:1000

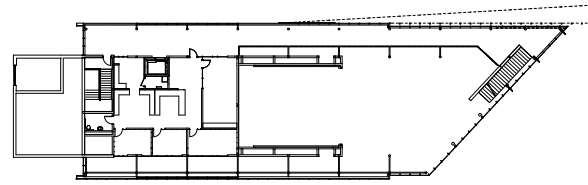

Second floor

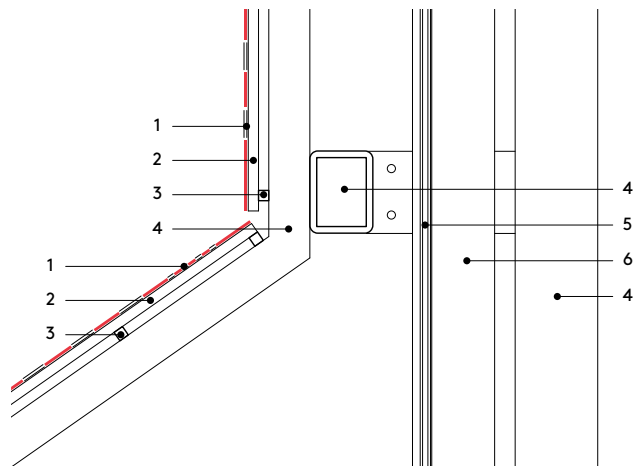
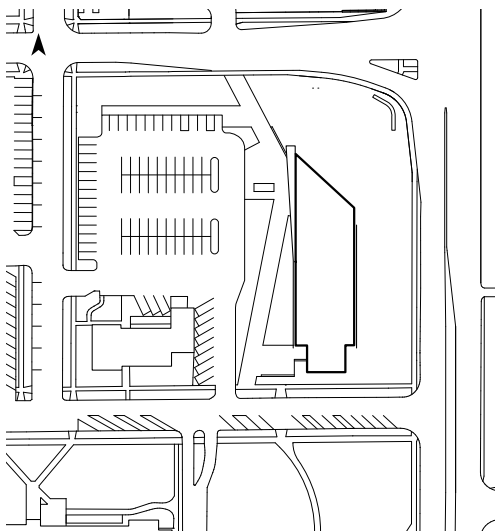

Vertical section 1:20

- 1 Swisspearl® LARGO panel 8 mm, perforated
- 2 ventilation cavity, aluminum sub framing
- 3 aluminum sub framing
- 4 structural steel
- 5 glazing
- 6 curtain wall system





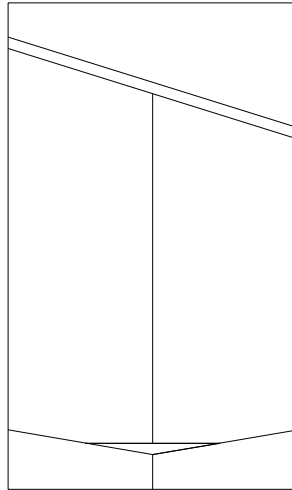

KINDERGARTEN, CERKVENJAK, SLOVENIA

LOCATION: Cerkvenjak 34 CLIENT: Občina Cerkvenjak

ARCHITECT: Superform, Ljubljana (Marjan Pobiljšaj, Anton Žižek, Špela Gliha, Meta Žebre, Boris Janje)

BUILDING PERIOD: 2010–2014 GENERAL CONTRACTOR: Gradbeništvo Milan Pintarič, Gornja Radgona

FAÇADE CONTRACTOR: LESAM, Miklavž na Dravskem polju FAÇADE MATERIAL: Swisspearl® LARGO, CARAT Topaz 7073

Architects Superform drew the inspiration for this kindergarten from a nearby learning path running through the Slovenian village of Cerkvenjak. Envisaged as an additional branch of this path, the building features an almost biomorphic plan layout consisting of six individually articulated units strung along an elongated central hallway. Five of the units provide play areas; the sixth accommodates administrative offices and an underground service level. The design concept allows the new facility to conform to the characteristics of the built and natural environment, as the stepped hallway follows the slope of the terrain while the gable-roofed playroom units approximate the geometry and scale of the neighboring residential houses. Intended to enrich the children's spatial experience, the

hallway itself varies in width and each playroom unit boasts a unique, irregular and contorted shape.

The design of the envelope supports this idea. The units are sheathed in a copper-colored Swisspearl paneling that incorporates a series of oblique ceiling-high window slits. Equally tilted, isochromatic timber posts propping up the eaves over the verandas create a mirror image of the façade cladding by inverting the pattern of solid and void elements. Taking advantage of the relative independence of weather skin and substructure, the architects left gaps between the panels to create a perforation-like shadow effect, which evokes the silhouettes of flying birds and gives additional visual interest to the façade.

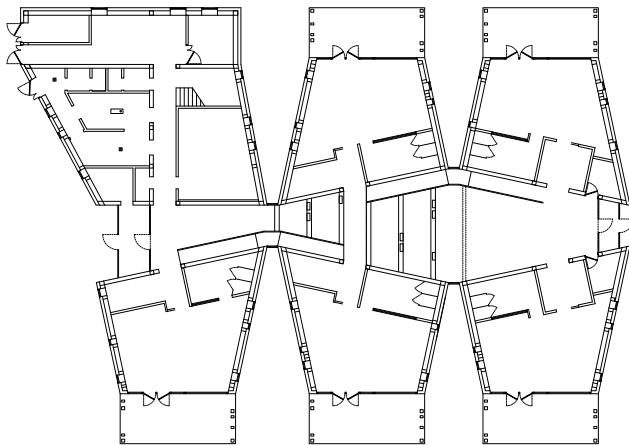

First floor 1:500

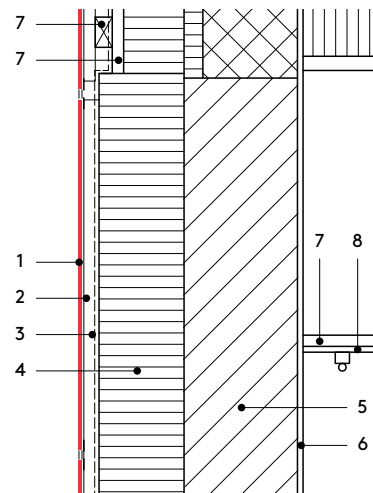

Vertical section 1:20

- 1 Swisspearl® LARGO panel 8 mm
- 2 ventilation cavity, vertical sub framing
- 3 moisture barrier
- 4 thermal insulation, mineral wool
- 5 brickwork
- 6 plaster
- 7 sub framing
- 8 gypsum board



MASHRABIYYA THE ORNAMENT AS VISUAL CONCEPT

Essay by Thomas Meyer-Wieser

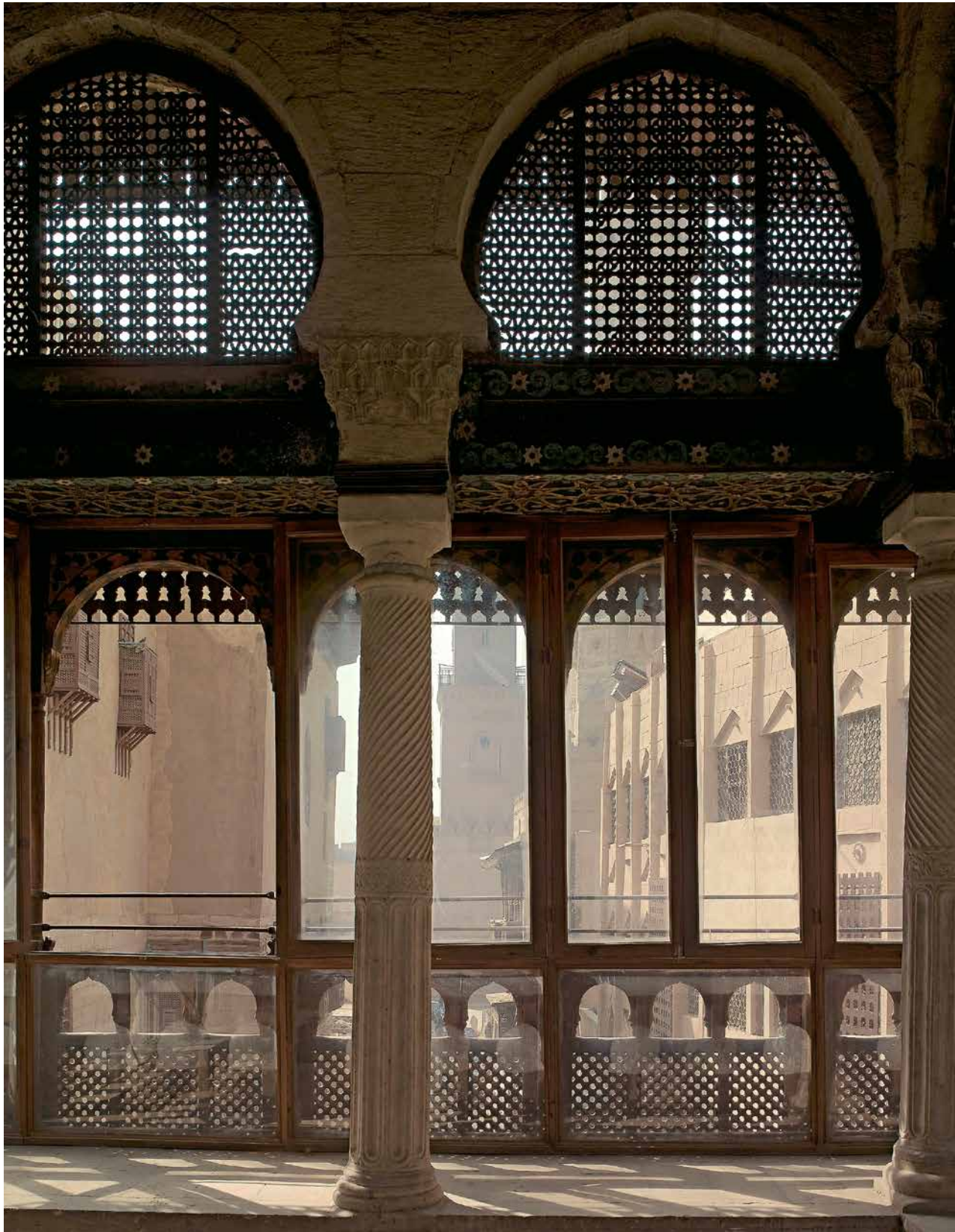

Increasing density in Arabic metropolises during the Ottoman Empire opened hitherto private inner courtyards to the public. In order to prevent people from looking into the living spaces on the upper floors, a new solution was necessary: mashrabiyya. Mounted in front of windows, loggia, and balconies, the artful, close-mesh wood latticework serves as a screen and protects from direct sun and also intense illumination. The influential Egyptian architect Hassan Fathy helped mashrabiyya to a revival in Egyptian post-war modernism.

Among all of the façade and furnishing elements in Arabic residential architecture, mashrabiyya is granted an entirely special meaning. With its geometrical motifs, carved and turned from wood, composed in one piece or elaborately cut from material, it creates a world of light and shadows that gives free rein to dreams. Set up in front of windows, loggia, and balconies, mashrabiyya serves as a screen and lattice to ensure the private sphere and protect from direct sunrays as well as intense illumination. People gather, for the most part, along the street facades of urban residential buildings and palaces in the Levant and Egypt. Since the production of mashrabiyya is time and cost intensive, they are considered an ornament of the rich.

Two theories explain the origins of the term “mashrabiyya”: in one, the word is meant to originate from “sharaba” (to drink) and can be traced back to the custom

of placing clay water jugs in window niches to allow the natural draft to cool the water. In another, the term is derived from “ashrafa” (to have an overview, observe) and was reworked over the course of the centuries under the influence of non-Arabic speakers.

Harâm—demarcated private sphere

The exact origins of mashrabiyya are unknown. The earliest examples are meant to date back to the twelfth century. Most of those preserved today, however, were created in the sixteenth century. Mashrabiyya also spread increasingly in Cairo during the Ottoman reign. They were mainly found in upper stories that jutted out into the street space and in many cases were furnished with wooden alcoves. Increasing density in the city led to new ground-plan solutions in monumental structures and residential architecture. Traditional house units became multistory, grouped around an inner courtyard so that the ground floor could be rented out as shops, living space, or stalls. The courtyard was no longer private, but instead, was used by several merchants and families.

The Islamic concept of protecting the interior of the house from foreigners thus became increasingly less important. In major cities, previously entirely closed outer walls were replaced with a partially porous external skin. Great care was taken not to injure a space’s protecting wall: Unnecessary window openings toward the street were avoided or—when necessitated by the climate—were covered by close-meshed wood latticework. The curtain of wood latticework creates the illusion of a continuous

Left: Koran school Sabil-Kuttab Abd al-Rahman Katkhuda, Cairo, 1744.

Residential palace Bayt Ahmad Kathuda al-Razzaz, Cairo, Fifteenth century/1778: mashrabiyya towards the courtyard.

Right: Bayt al-Kiridliya, Cairo, sixteenth/seventeenth centuries: private living space (haramlik) on the upper floor.

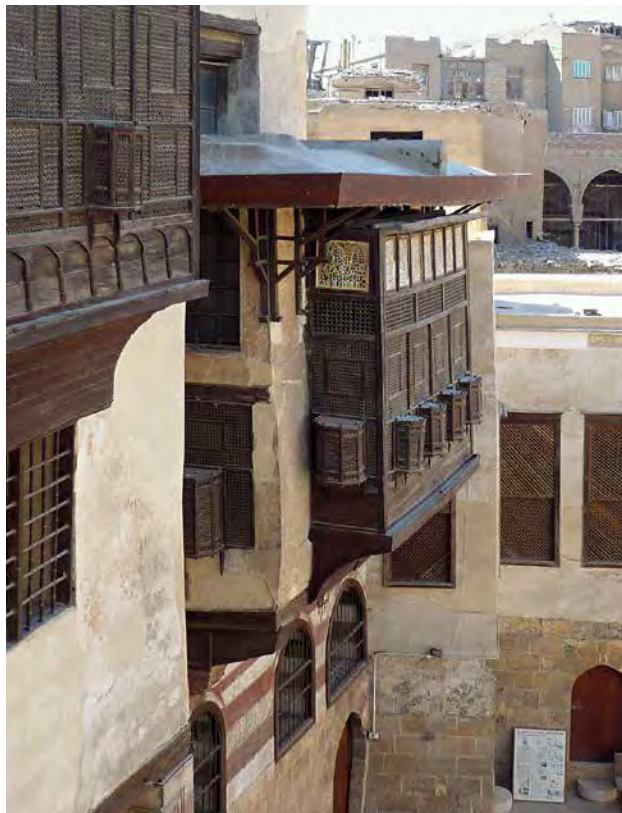

external skin, which nonetheless permits adequate incidence of light and attractive views. Viewed from outside, the woodwork appears as a dominant element of the façade.

Filter for space and mind

The new residential model and upgrading of the street as a protected exterior space led to the façade's clear and symmetrical organization by alcove and window, even perforations, thus allowing it to fulfill the growing demand for light, air, and sun. A broad alcove on the first floor often subdivided the visible face. Behind it was usually the main reception space, thus making the interior structure legible from outside.

The window zone was, however not merely an opening in the wall, but instead, presented a specific vertical spatial level cut into the wall: as a rule, it was gridded in order to separate inside and outside, private and public. Light penetrated the interior as though through a dense filter.

For windows facing the house's own inner courtyard, soffits were often fitted with low balustrades that served as shelves or benches. In most cases, alcove-like outgrowths arose, which turned the mashrabiyya window into an overhanging spatial niche from which one could look outward, while either sitting or reclining. However, this was not only a unique type of window design, but also frequently a considerable expansion of living space for the inhabitants and at the same time, welcome shade for people on the street. In the case of street-side windows, protective measures had to be intensified, whereby inhabitants remained out of sight from the passersby on the street, while, in reverse, they were able to secretly observe the goings-on outside.

Nomadic architecture

The spaces in a traditional Arabic house were used in ways more flexible and diverse than is the case in modern European life. In Europe, individual functions—eating, sleeping, household, and reception—have been divided since the turn from the seventeenth to eighteenth century. In addition, heavy furniture designed specifically for a particular purpose clearly and immutably defines the specific function of individual spaces.

The Muslim house generally knew only light and mobile interior furnishings and in that, remained entirely true to the character of the tent: the customary seating on the floor called for carpets and cushions rather than chairs; tables consisted of low, foldable bases and movable copper panels, but often a cloth spread out on the carpet sufficed; niches built into walls replaced cupboards. Long, flat, upholstered benches ran along the walls or along the window sides and served for sleeping, reclining, sitting, or offered a backrest for those sitting on the floor. Conventional differentiation into bedroom, liv-

ing room, and study were hereby dispensed with, as the same space could fulfill these functions successively at different times, and could be rearranged with just a few simple moves.

Ornament is no crime

The diversity of uses of the space leads to leaving the rooms nearly empty. Consequently, the surfaces of floor, ceilings, and walls are more important than furniture. Symmetrically cut window openings, screened by the filigree net of the mashrabiyya, wall niches, geometrically subdivided wall friezes, ceiling decorations, floor mosaics, and carpets as well as artistically designed equipment placed on select sites lend the lined space a clear inner order, which does not exclude the accidental, but instead, gives it a solid frame.

Monumental building dimensions and delicate decoration, is and remains a typical tension in Islamic architecture. With the tendency towards dematerialization, a central characteristic steps forth that corresponds with the non-representational character of the fine arts of Islam. Here, the aspiration is for a refining of the senses in order to awaken to a higher reality rather than a negation of sensual experience or escape into transcendence. For that, the architectural shell must shed its earthly weightiness and take on an ethereal state, which is possible with the help of the ornament.

Reservoir of forms and ideas

This aspect of Islamic art contributed decisively to the discovery of a new, truly modern artistic language in Europe in the first decades of the twentieth century. Walter Gropius and Le Corbusier successfully developed an architecture that appeared to break radically with tradition and orient on entirely new principles. Both architects worked intensely with oriental architecture: Gropius had spent nearly a year in Spain studying Moorish art in 1907, and Le Corbusier traveled through Turkey together with his friend Klippstein in 1911. Ottoman architecture offered him a reservoir of ideas and forms for interior design and proportion theory.

Even representatives of Bauhaus grappled intensely with the principles of Islamic art, as shown in the works of Wilhelm Wagenfeld produced in 1923/24 under the influence of Johannes Itten in the metal workshop. Presenting a climax of this movement was the "Meisterwerke Muhammedanischer Kunst" exhibition, which took place in Munich in October 1910. The exhibition initiated an investigation of Islamic art in the West and met with a positive response in painting. Rather than an interest in the exotic content of oriental art, artists were fascinated by the two-dimensional approach of Islamic painting, which corresponded with their own strivings. Accordingly, the image should, primarily, be a two-dimensional object and should be perceptible as such.



Two structures by Hassan Fathy in Egypt: Akil Sami House, Dahshur, 1978 (left), and the oasis village New Baris, Kharga, 1967.



Staging of light

Under the pretext of fiction, Hassan Fathy published personal, often critical views on questions related to modernism, tradition, and architectural heritage. In 1942 he wrote the fable “Quissat al-mashrabiyya (Tale of the Mashrabiyya),” in which the filigree geometric network of the mashrabiyya of a fourteenth-century palace plays an important role: “It was dense and detailed up to eye height, above that, wide-meshed and open so that light appeared when it took its course through the space in the rhythm of the times of the day.”

Fathy thus interprets the mashrabiyya through the play of light as an inward-turned light shade rather than an opening to the outside. While in the West, the window marks the location of the subject who gazes curiously out into the world, in the Arabic space, a grid is built at this threshold, which serves entirely for the staging of light. In this, light itself becomes a theme of geometry. It separates from the material carrier of the window grid and circulates freely in changing refractions and various corners of the space. In this way, the mashrabiyya lends light a shape, which first forms in the interior of the house. The built space is the stage on which light appears as a cosmic power as the play of light rays runs its course through the inside space following the rhythm of the times of day.

Through the return to the mashrabiyya, Fathy adopted not only an artistic, but also a political position. He represented the view that architects should strengthen national pride by taking up and further developing traditional construction forms. Fathy worked closely with

other artists and was also active in teaching. Although most of his projects remained unbuilt and some of his structures have been transformed or destroyed, Fathy was nonetheless one of the most important figures of identification for several generations of Egyptian architects and the Egyptian-Arabic art scene.

Literature

Stefano Bianca, *Hofhaus und Paradiesgarten. Architektur und Lebensformen in der islamischen Welt*, Munich 1991/2001.– Hans Belting, *Florenz und Bagdad. Eine westöstliche Geschichte des Blicks*, Munich 2008.– Leila el-Wakil, *Quissat al-mashrabiyya (Le Conte du Moucharabieh). Enraciner l'architecture appropriée: Hassan Fathy*, (Genève) 2013.– Markus Hattstein, Peter Delius, *Islam: Kunst und Architektur*, Cologne 2000.– Wolfgang Mayer, Philipp Speiser, *Der Vergangenheit eine Zukunft. Denkmalpflege in der islamischen Altstadt von Kairo 1973–2004*, Mainz 2007.– Stefan Weber, *Zeugnisse kulturellen Wandels*, PhD thesis. Berlin 2001.

Book recommendation

Thomas Meyer-Wieser published an architectural guide to Cairo in 2014. Based on more than 200 buildings as examples, he describes the concept of this north-African city, which was once the heart of high culture in antiquity, and is today the capital of modern Egypt. More so than any other city in the Islamic world, Cairo stands for architectural and social transformation, for the charged field between religious tradition and a modern world of glitz. The metropolis of eighteen million is rightly so considered the “mother of all cities.” (*Architekturführer Kairo*, 388 pages, Berlin 2014)

SMALL FORMAT

EMBROIDERED FAÇADE

Detailed fiber cement panels decorate the rectory in the rural community of Degersheim. They form a uniform protective layer, similar to the way wood shingles once did, and are reminiscent of textiles. Various formats in successive rows reveal a site-specific design approach.

MICHAEL HANAK The rectory is next to the church, in the center of town. Degersheim is a community in the hilly pre-Alpine region of the Canton of St. Gallen. Two mighty church structures define this nationally significant townscape: the reformed church built by Curjel & Moser in 1906/07 in a traditional *Heimatstil* and the Catholic St. Jakobus Church built by the local architects Danzeisen & Hunziker in 1924 in a neo-baroque style.

Many homes in town correspond with the style of the Stickerhaus where embroidery machines were once found in the stonewalled semi-basement, and people resided on the two upper floors. The facades of the upper floors were protected with wood shingles, which were occasionally painted in lightly tinted shades as a refining touch. The repetition of these qualities led to a uniform townscape.

Architect Hans Ruedi Stutz, who is active in town, grappled with local building tradition for the rectory project. For the new structure, he interpreted the typical local Stickerhaus in a contemporary way. “The new rectory follows design principles from the heyday of the embroidery factory,” says Hans Ruedi Stutz. “Nonetheless, it reveals a contemporary ground plan, structures, and materials and blends them together to a whole that integrates harmoniously into the townscape, which is worthy of protection.”

The house has three floors and ends with a flat hip roof. The ground floor is plastered, the upper floors are clad with fiber cement panels. A fascia is added for organization above the ground floor, which like the window casing is composed of prefabricated concrete elements. Pilaster strips built from flat painted wood panels run along the corners of the building. With its detailed shingle cladding reminiscent of tradition,

and the classical organizing elements, the building blends harmoniously into the townscape.

“The Swisspearl shingles that are used continue the tradition of the existing stock; with their detail, they shape a homogenous texture for the façade,” says Stutz. “The use of different formats and cuts plays with the idea of textiles, generating a liveliness that guides the attention of passersby towards it. The façade is the ‘dress’ of the typical embroidery building. Its design is a clear reminiscence of the embroidery factory and the former sensually-playful building tradition, which is underscored by the use of a floral pattern—the façade appears as though embroidered.”

In order to evoke a similarity with traditional wood shingles, on the one hand, and the reminiscence of the typical local embroidery factory, the choice of façade material quickly fell on detailed fiber cement panels. At first, the architects considered combining two tones of gray and alternating them stripe-wise. With this, they aimed to achieve an embroidery effect. However, in the sampling they assessed that there was too much contrast. Therefore, they decided on only one color tone: greenish-gray, pale beige.

In the choice of formats, diversity and variety were welcome. A dynamic stripe pattern was meant to arise as in linear embroidery patterns. Squares, rectangles, and rhombuses alternate in one to three rows. Depending on the level and intensity of the sun, but also the close or distant perspective, a finely woven façade pattern arises visually rendering the architects’ design approach.

Rectory, Degersheim, Switzerland

LOCATION
Steineggstrasse 23, Degersheim

CLIENT
Parish Degersheim

ARCHITECTS
architektur.stutz, Degersheim
(Hans Ruedi Stutz, Sanae Mukai, Florian Oertli, Antonios Palaskas)

BUILDING PERIOD
2014/15

FAÇADE CONTRACTOR
Giger GmbH, Degersheim

FAÇADE MATERIAL
Swisspearl® NOBILIS
Beige N 811
5 × 120 × 150 cm and
10 × 60 × 150 cm and
5 × 120 × 150 cm



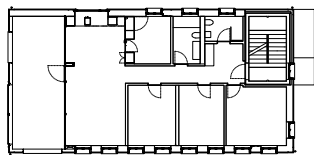

Second floor

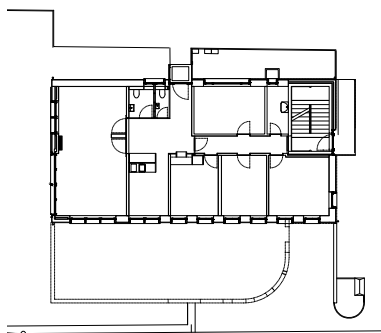

First floor 1:500

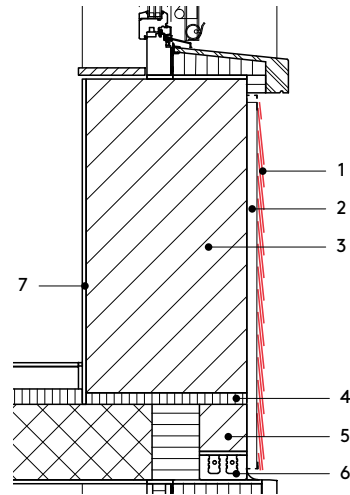

Vertical section 1:20

- 1 Swisspearl® SMALL FORMAT 4 mm
- 2 ventilation cavity, vertical batten
- 3 thermal block
- 4 acoustic insulation layer
- 5 brickwork
- 6 prefabricated lintel
- 7 plaster



The parish's façade of small-format panels continues the local building tradition.

The small size panels have vertical cuts. Overlapping one another, each part seems to be attached individually. The accurate vertical and horizontal alignment makes the panels look smaller than they actually are. The precisely fit installation lends a continuous and homogeneous effect to the cladding.



Publisher

**SWISS
pearl**®

CH-8867 Niederurnen
Switzerland
phone +41 (0)55 617 11 60
info@swisspearl.com
www.swisspearl.com

The internationally distributed magazine *Swisspearl Architecture* sets Swisspearl fiber cement products within a contemporary architectural context.

Advisory board

Michèle Rüegg Hormes,
division manager communication,
Dept. of Architecture, ETH Zurich
Martin Tschanz, docent ZHAW

Editorial committee

Michael Hanak
Martina Kast
Marco Pappi
Jürg Schönenberger
Yasmin Willi
Robert Wirichs

Editor

Michael Hanak, Zurich

Editing

Marion Elmer, Zurich

Translation

Lisa Rosenblatt, Vienna

Design

Bernet & Schönenberger, Zurich

Detail plans

Deck 4 GmbH, Zurich

Printing company

Galledia AG, Flawil

Print run

20,000

Typeface

Brown Pro, Mercury Text

English edition

ISSN 1661-3260

Authors

Michael Hanak is a Zurich-based historian specialized in art and architecture. He has a preference for contemporary architectural history and the current handling of it.

Patrick Zamariàn is a freelance writer and translator. For his PhD thesis at the University of Liverpool, his focus is on British postwar architecture.

Thomas Meyer-Wieser, architect and urban planner, has been involved with the architecture and urban planning of the Islamic world since his studies at the ETH Zurich: 1974 internship in Teheran, 1979 restoration of the Palace Ghala Dokhtar in Firuzabad, Iran, travel stipend and research on Hassan Fathy. 1995–2002 lectureship landscape architecture, Hochschule für Technik Rapperswil. Own architecture firm in Feldmeilen, Switzerland.

Photos

C1: Fernando Guerra, Lisbon
C2: Marc Petitjean, Paris
C3: Kilian J. Kessler, Zurich
C4: Miran Kambič, Radovljica

pp. 2/3: Swisspearl, Niederurnen
pp. 4/5: Kilian J. Kessler, Zurich
pp. 6/7, 16–19: Nils Timm, Los Angeles
pp. 8–11: Ruedi Walti, Basel
pp. 12–15: René Riller, Schlanders
pp. 20–33: Jürg Zimmermann, Zurich
pp. 34–39: Sandro Lendler, Zagreb
pp. 40–45: Fernando Guerra FG + SG, Lisbon
pp. 46–49: Albertszki Tamás, Budapest
pp. 50–55: Gayle Babcock, Springfield
pp. 56–59: Miran Kambič, Radovljica
p. 60: B. O’Kane/Alamy
p. 61 left: Stefan Bischof, Zurich
p. 61 right: Thomas Meyer-Wieser, Feldmeilen
p. 63: Danielle Fischer, Zurich
pp. 64–67: Jürg Zimmermann, Zurich

Legal notes

Texts, images, photos and graphic work in this publication are protected by copyright and other intellectual property rights. Rights to the texts are owned by the writers in all cases. The contents of this publication may not be copied, distributed, altered or made available to third parties for commercial purposes. Further, some pages include images the copyrights of which are owned by third parties.

This publication has been assembled with the greatest possible care. Nevertheless, the publisher cannot guarantee freedom from error and the complete accuracy of the information it contains. The plans have been kindly provided by the architects. The detailed plans have been reworked for greater legibility; the editors are not able to guarantee their accuracy.

Except for CARAT Onyx and Amber, all fiber cement panels Swisspearl® LARGO are manufactured exclusively in Switzerland.

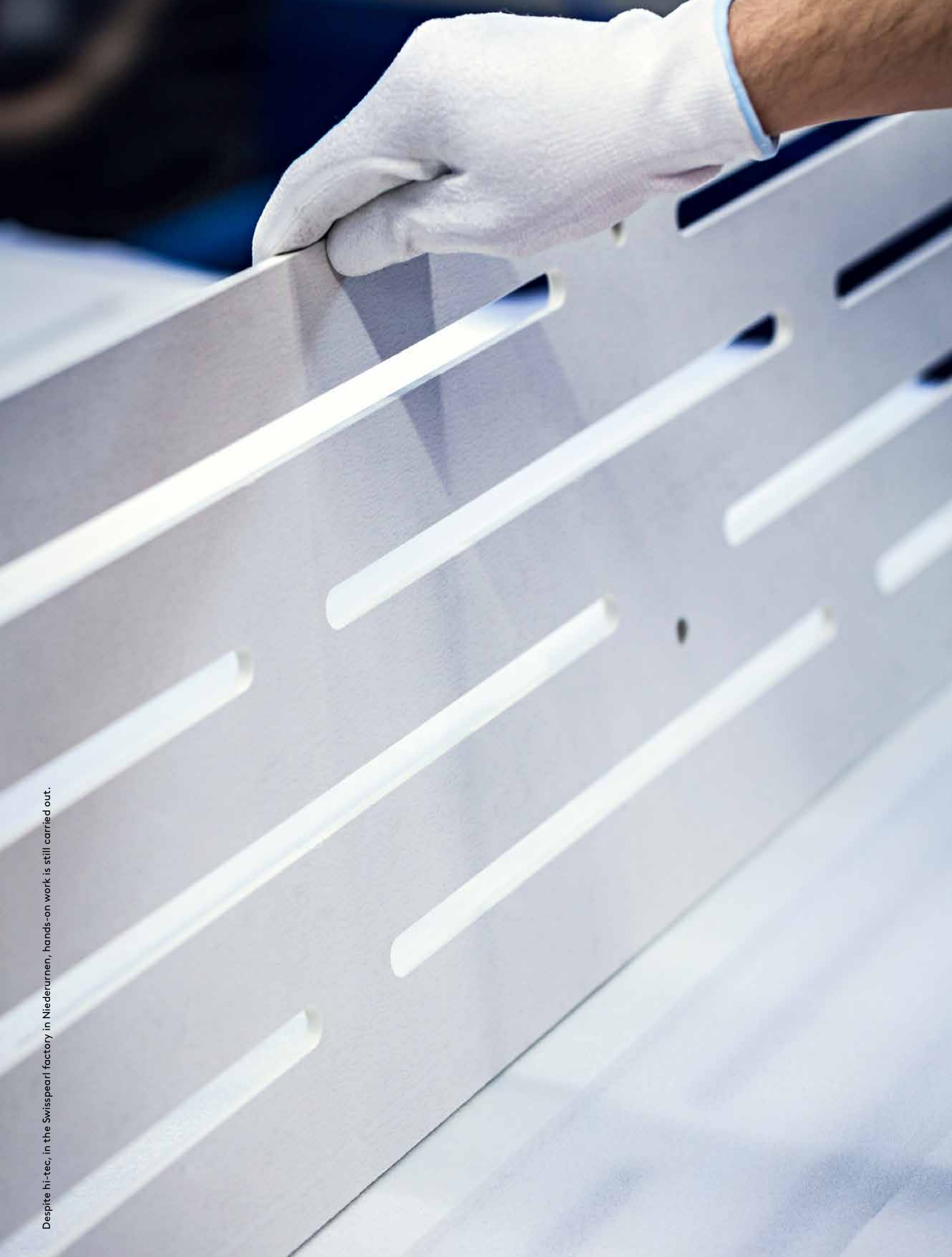

Despite hi-tec, in the Swisspearl factory in Niederurnen, hands-on work is still carried out.

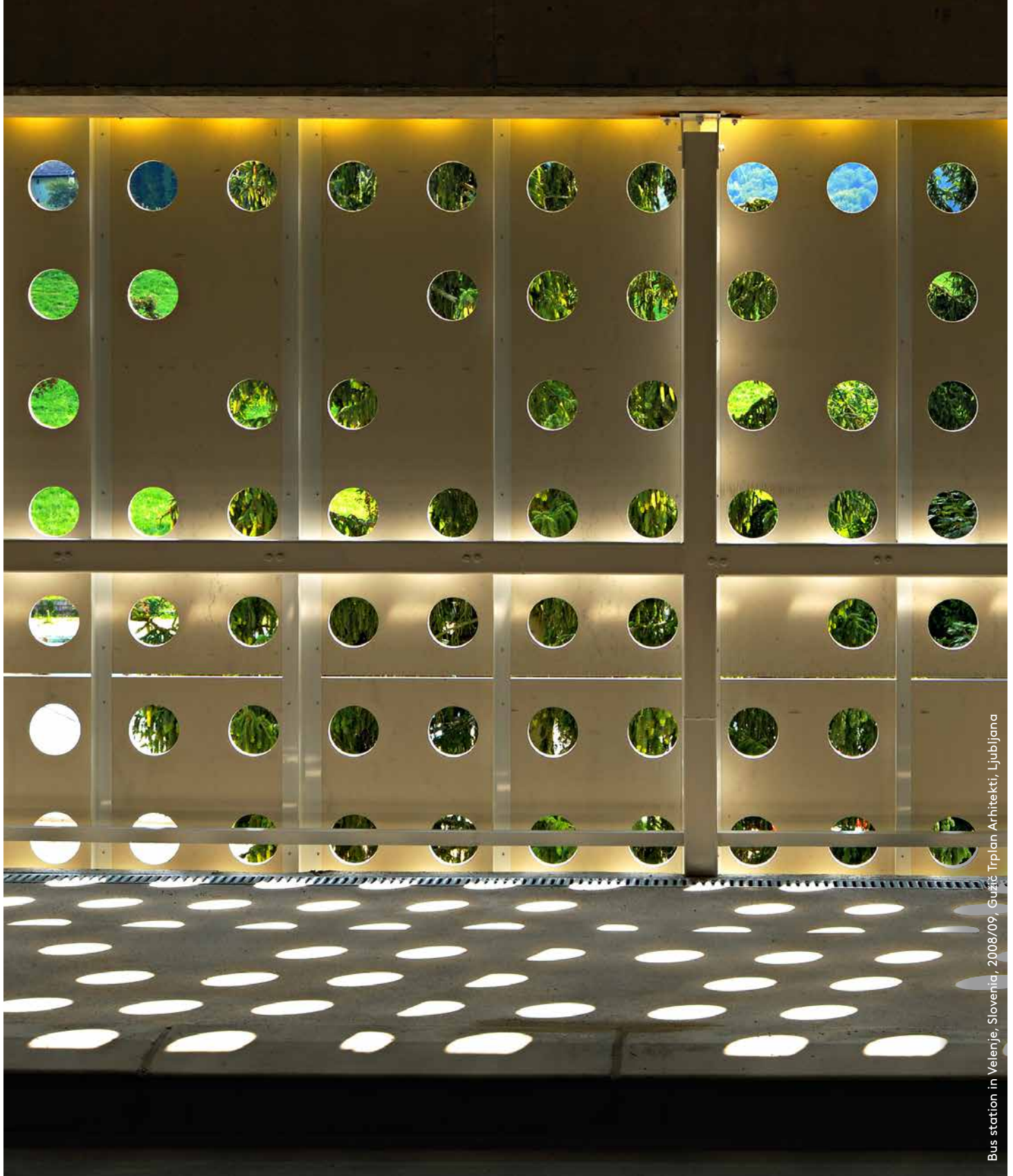

Bus station in Velenje, Slovenia, 2008/09, Gušić Trplan Arhitekti, Ljubljana

PERFORATED

Openings that let in light and air are among the most basic characteristics of a building envelope. Perforations are perfectly suitable for opening exterior walls in a purposeful and controlled way. At the same time, they create an impressive appearance. As can be seen on many of today's façades, perforations form patterns and ornaments—a contemporary variation of the centuries-old Arabic tradition of mashrabiyya. Small or large openings, drilled or cut, connect technical matters with aesthetic demands. This issue of *Swisspearl Architecture* presents various designs for perforated façade panels, and also, how they can be applied.